

HALFEN HIT INSULATED CONNECTION

EUROPEAN TECHNICAL ASSESSMENT ETA-18/0189

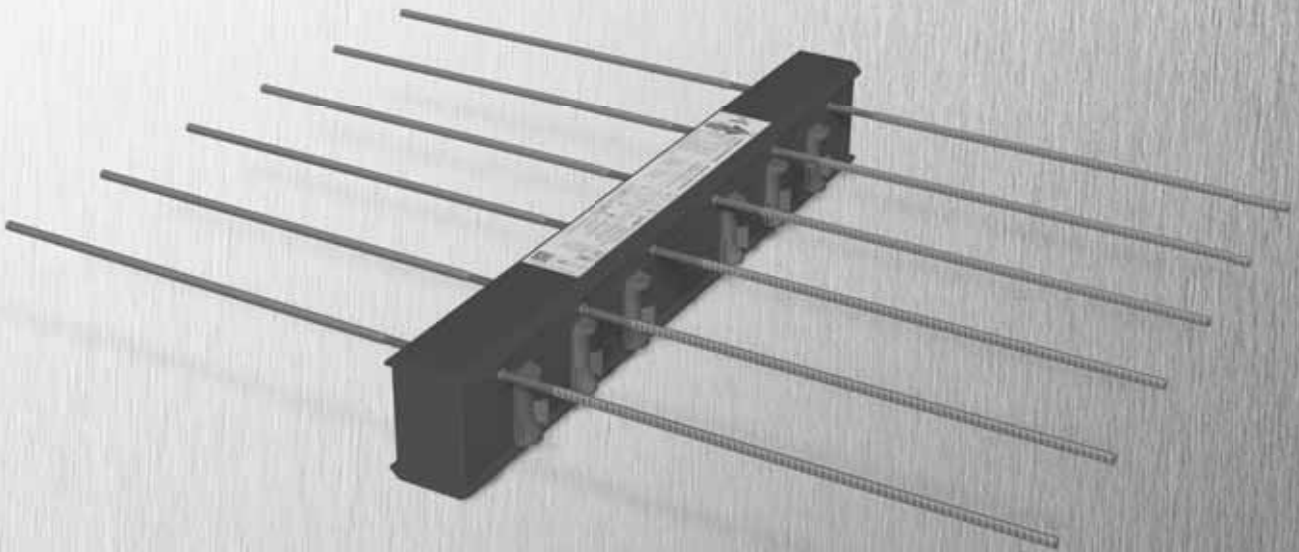

HALFEN HIT INSULATED CONNECTION

ETA_HIT-HP-SP 06/18-E

CONCRETE



HALFEN

A CRH COMPANY

HALFEN HIT INSULATED CONNECTION

General note

Use of third-party products

This approval only applies to original HALFEN products manufactured by HALFEN. The specifications in this approval are not transferable to other products. Users are fully liable for personal injuries and material damage caused by third-party products used instead of HALFEN products.

Approval body for construction products
and types of construction

Bautechnisches Prüfamt

An institution established by the Federal and
Laender Governments



European Technical Assessment

ETA-18/0189
of 21 June 2018

English translation prepared by DIBt - Original version in German language

General Part

Technical Assessment Body issuing the
European Technical Assessment:

Deutsches Institut für Bautechnik

Trade name of the construction product

Halfen Insulated Connection HIT-HP/SP

Product family
to which the construction product belongs

Load bearing thermal insulating elements which form a
thermal break between balconies and internal floors

Manufacturer

Halfen GmbH
Liebigstraße 14
40764 Langenfeld
DEUTSCHLAND

Manufacturing plant

Halfen GmbH
Otto-Brünner-Straße 3
06556 Artern
Germany
HALFEN Produkcja
ul. Kolejowa 18a
Nowe Sklamierzyce, 63-460
Poland

This European Technical Assessment
contains

45 pages including 4 annexes which form an integral part
of this assessment

This European Technical Assessment is
issued in accordance with Regulation (EU)
No 305/2011, on the basis of

EAD 050001-00-0301

The European Technical Assessment is issued by the Technical Assessment Body in its official language. Translations of this European Technical Assessment in other languages shall fully correspond to the original issued document and shall be identified as such.

Communication of this European Technical Assessment, including transmission by electronic means, shall be in full. However, partial reproduction may only be made with the written consent of the issuing Technical Assessment Body. Any partial reproduction shall be identified as such.

This European Technical Assessment may be withdrawn by the issuing Technical Assessment Body, in particular pursuant to information by the Commission in accordance with Article 25(3) of Regulation (EU) No 305/2011.

Specific part

1 Technical description of the product

The Halfen Insulated Connection HIT-HP/SP is used as load-bearing thermal insulating element to connect reinforced concrete slabs.

The product description is given in Annex A.

The characteristic material values, dimensions and tolerances of the Halfen Insulated Connection HIT-HP/SP indicated in Annexes A1 to A14 shall correspond to the respective values laid down in the technical documentation^[1] of this European Technical Assessment.

2 Specification of the intended use in accordance with the applicable European Assessment Document

The performances given in Section 3 are only valid if the Halfen Insulated Connection HIT-HP/SP is used in compliance with the specifications and conditions given in Annex B.

The verifications and assessment methods on which this European Technical Assessment is based lead to the assumption of a working life of the Halfen Insulated Connection HIT-HP/SP of at least 50 years. The indications given on the working life cannot be interpreted as a guarantee given by the producer, but are to be regarded only as a means for choosing the right products in relation to the expected economically reasonable working life of the works.

3 Performance of the product and references to the methods used for its assessment

3.1 Mechanical resistance and stability (BWR 1)

Essential characteristic	Performance
Load bearing capacity	See Annex C1

3.2 Safety in case of fire (BWR 2)

Essential characteristic	Performance
Reaction to fire of materials	See Annex A14
Resistance to fire	See Annex C2

3.3 Protection against noise (BWR 5)

Essential characteristic	Performance
Impact sound insulation	See Annex C6

3.4 Energy economy and heat retention (BWR 6)

Essential characteristic	Performance
Thermal resistance	See Annex C4 – C5

^[1] The technical documentation of this European technical assessment is deposited at the Deutsches Institut für Bautechnik and, as far as relevant for the tasks of the approved bodies involved in the attestation of conformity procedure, is handed over to the approved bodies.

4 Assessment and verification of constancy of performance (AVCP) system applied, with reference to its legal base

In accordance with EAD No. 050001-00-0301, the applicable European legal act is: [1997/0597/EC].

The system to be applied is: [1+]

5 Technical details necessary for the implementation of the AVCP system, as provided for in the applicable EAD

Technical details necessary for the implementation of the AVCP system are laid down in the control plan deposited with Deutsches Institut für Bautechnik.

The following standards are referred to in this European Technical Assessment:

- EN 206-1:2000 Concrete – Part 1: Specification, performance, production and conformity
- EN 1992-1-1:2004 + AC:2010 Eurocode 2: Design of concrete structures – Part 1-1: General design rules and rules for buildings
- EN 1993-1-1:2005 + AC:2009 Eurocode 3: Design of steel structures – Part 1-1: General design rules and rules for buildings
- EN 1993-1-4:2006 + A1:2015 Eurocode 3: Design of steel structures – Part 1-4: General rules – Supplementary rules for stainless
- EN 10088-1:2014 Stainless steels – Part 1: List of stainless steels
- EN 12664:2001 Thermal performance of building materials and products – Determination of thermal resistance by means of guarded hot plate and heat flow meter methods – Dry and moist products of medium and low thermal resistance
- EN 13162:2012+A1:2015 Thermal insulation products for buildings - Factory made mineral wool (MW) products - Specification
- EN 13501-1:2007+A1:2009 Fire classification of construction products and building elements – Part 1: Classification using data from reaction to fire tests
- EN ISO 6946:2007 Building components and building elements – Thermal resistance and thermal transmittance – Calculation method (ISO 6946:2007)
- EN ISO 10211:2007 Thermal bridges in building construction – Heat flows and surface temperatures – Detailed calculations (ISO 10211:2007)
- EN ISO 10456:2007 Building materials and products – Hygrothermal properties – Tabulated design values and procedures for determining declared and design thermal values (ISO 10456:2007 + Cor. 1:2009)

Issued in Berlin on 21 June 2018 by Deutsches Institut für Bautechnik

Dr.-Ing. Lars Eckfeldt
p. p. Head of Department

beglaubigt:
Kisan

A.1 Type overview

Type HIT-HP/SP MVX

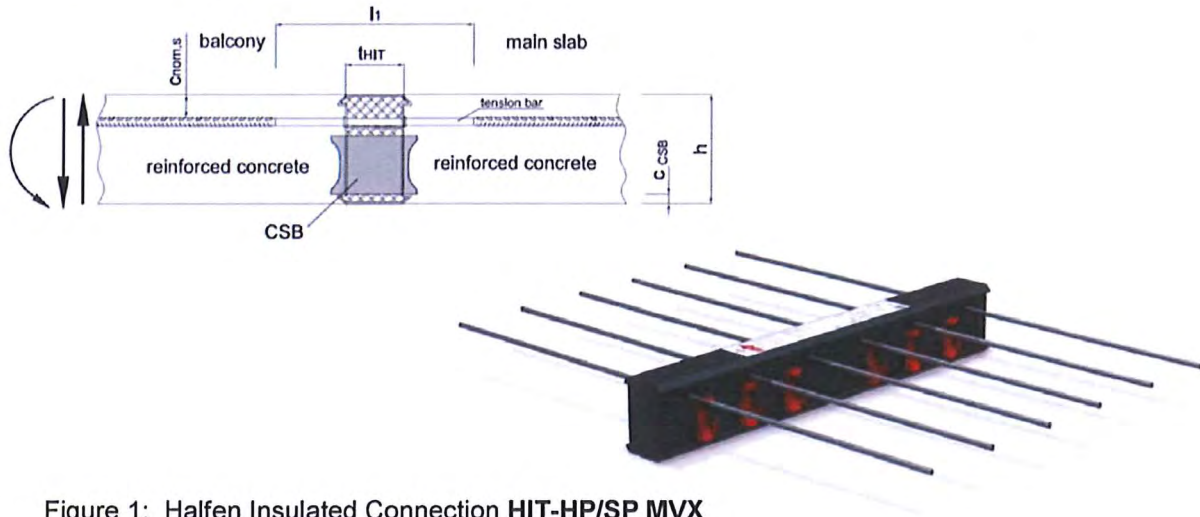

Figure 1: Halfen Insulated Connection HIT-HP/SP MVX

Type HIT-HP/SP MVX-...-OD

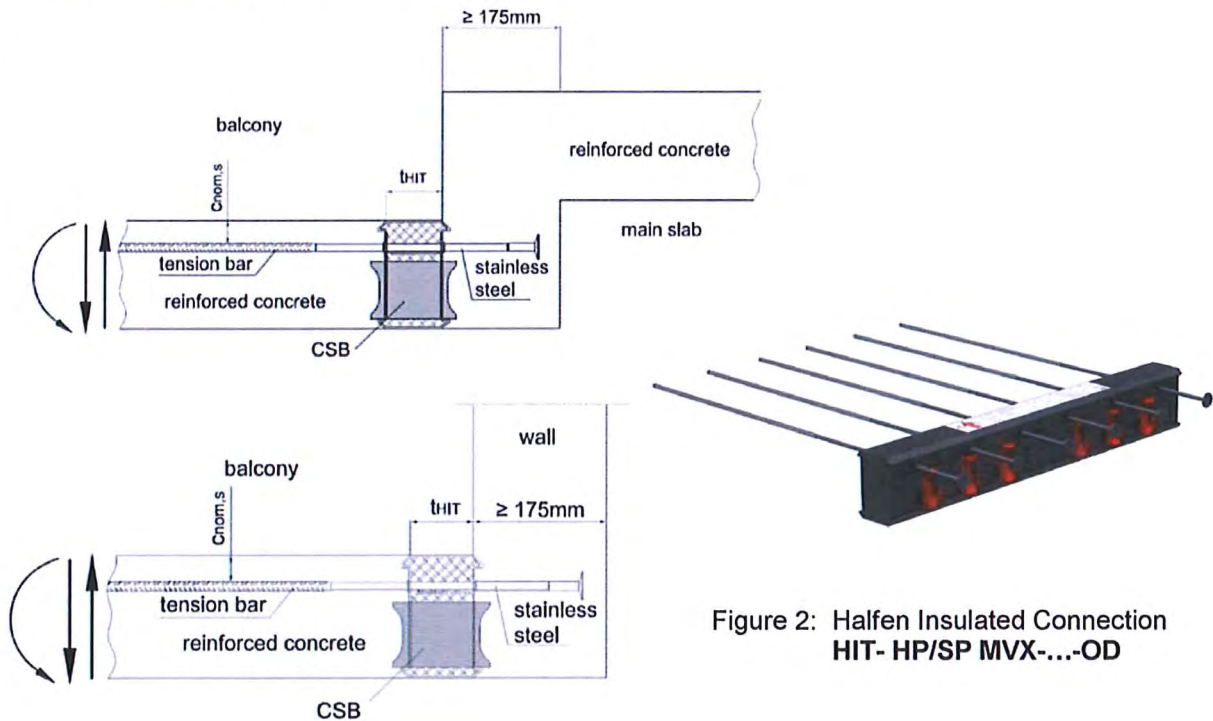

Figure 2: Halfen Insulated Connection HIT-HP/SP MVX-...-OD

Halfen Insulated Connection HIT-HP/SP

Annex A1

Product description
Element types

Type HIT-HP/SP MVX-...-OU

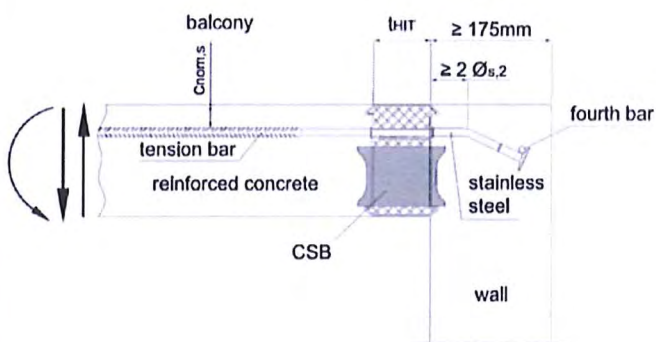
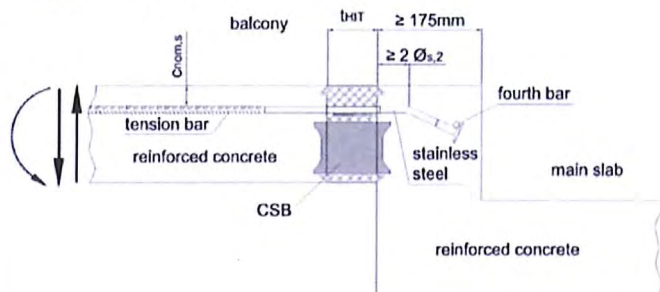

Figure 3: Halfen Insulated Connection
HIT- HP/SP MVX-...-OU

Type HIT-HP/SP MVXL

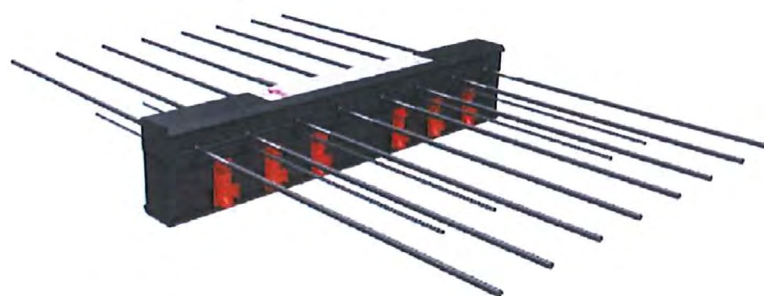
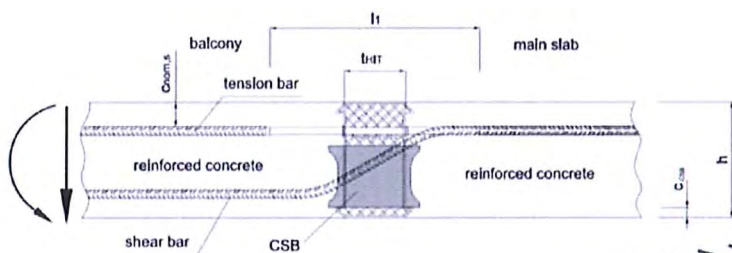

Figure 4: Halfen Insulated Connection HIT-HP/SP MVXL

Halfen Insulated Connection HIT-HP/SP

Product description
Element types

Annex A2

Type HIT-HP/SP ZVX

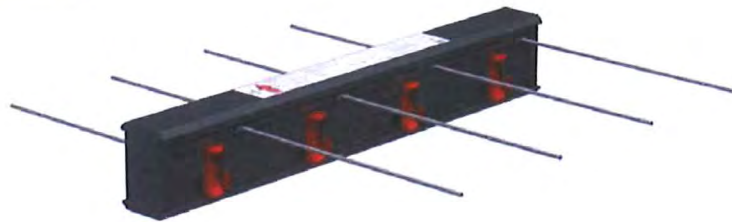
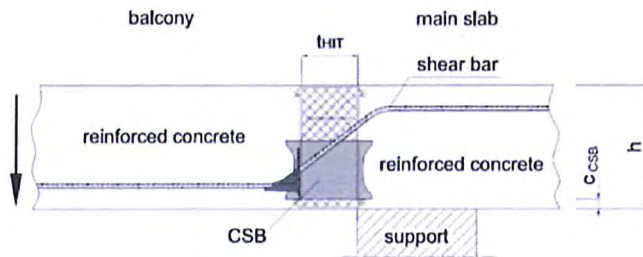

Figure 5: Halfen Insulated Connection HIT-HP/SP ZVX

Type HIT-HP/SP ZDX

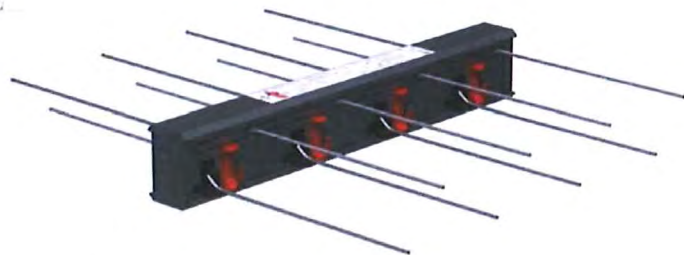
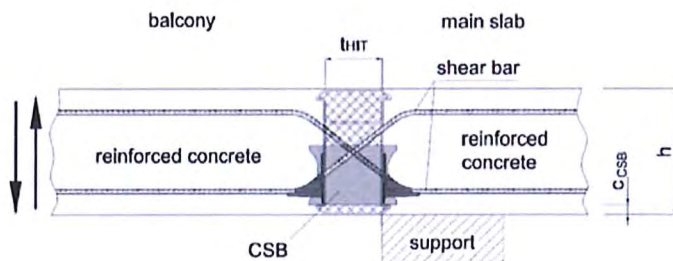

Figure 6: Halfen Insulated Connection HIT-HP/SP ZDX

Halfen Insulated Connection HIT-HP/SP

Annex A3

Product description
Element types

Type HIT-HP/SP DD

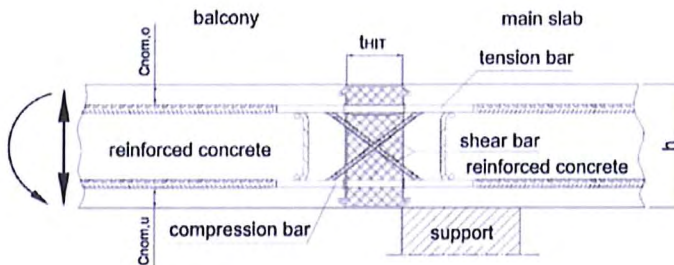

Figure 7: Halfen Insulated Connection HIT-HP/SP DD

Type HIT-HP/SP AT

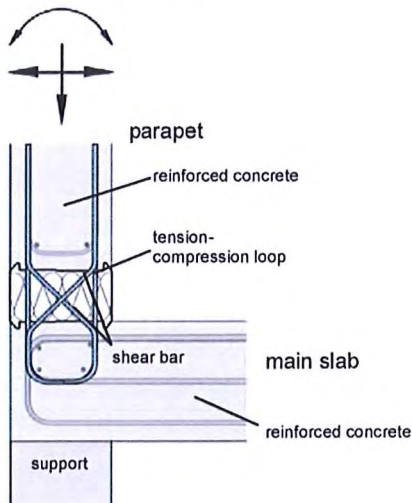

Figure 8: Halfen Insulated Connection HIT-HP/SP AT

Halfen Insulated Connection HIT-HP/SP

Annex A4

Product description
Element types

Type HIT-HP/SP FT

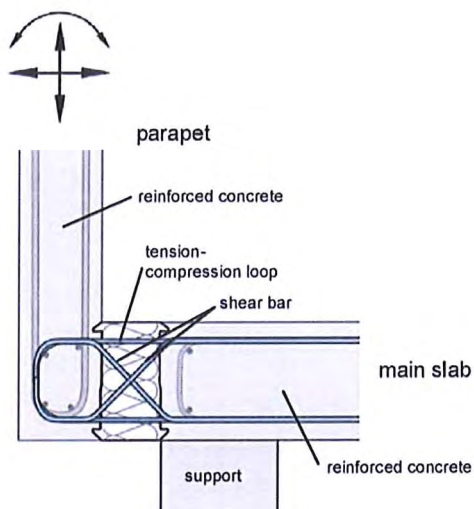

Figure 9: Halfen Insulated Connection HIT-HP/SP FT

Type HIT-HP/SP OTX

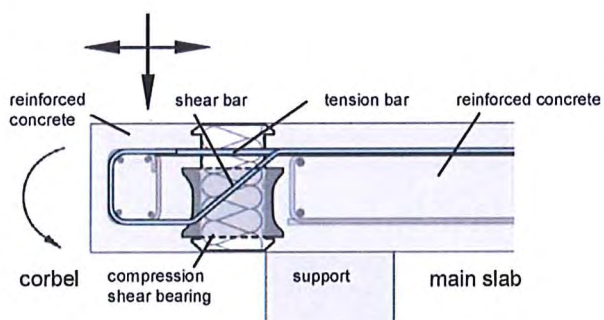

Figure 10: Halfen Insulated Connection HIT-HP/SP OTX

Halfen Insulated Connection HIT-HP/SP

Annex A5

Product description
Element types

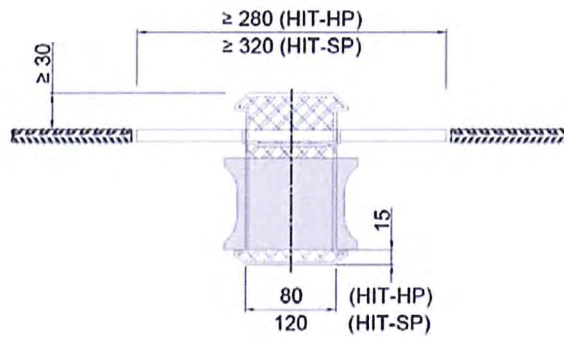

Figure 11: Halfen Insulated Connection HIT-HP/SP completed execution variation

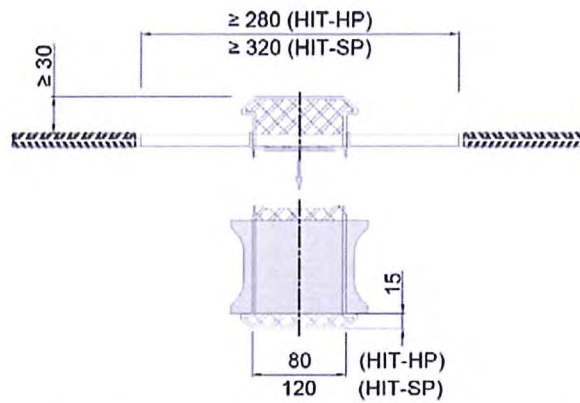

Figure 12: Halfen Insulated Connection HIT-HP/SP separated execution variation

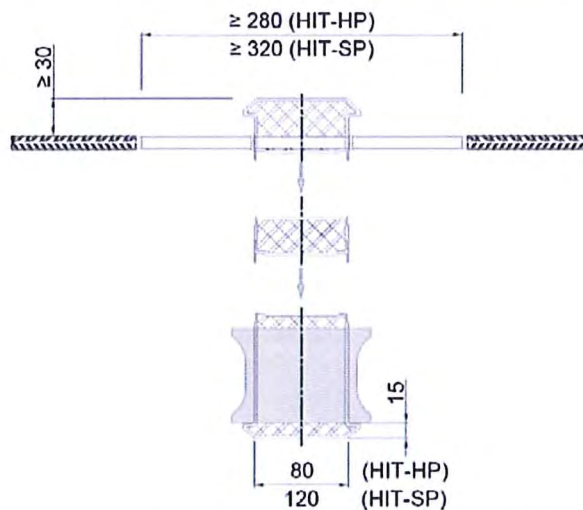

Figure 13: Halfen Insulated Connection HIT-HP/SP multi-part execution variation

Halfen Insulated Connection HIT-HP/SP	Annex A6
Product description Element types	

A.2 Dimensions and positioning of the bars and compression shear elements in the area of the insulation joint

HIT-HP/SP MVX (general)

- Element height h : $160 \text{ mm} \leq h \leq 500 \text{ mm}$
- Number of compression shear bearings per one-meter element n_{CSB} : ≥ 2 (for $h \leq 300 \text{ mm}$)
 ≥ 4 (for $h \leq 500 \text{ mm}$)
 ≤ 12
- Concrete cover of the compression shear bearings c_{CSB} : $\geq 15 \text{ mm}$
- Axial distance of the compression shear bearings to the lateral component edge: $\geq 80 \text{ mm}$
- Axial distance of the compression shear bearings: $\geq 75 \text{ mm}$
 $\leq 600 \text{ mm}$ (for $n_{\text{CSB}} = 2$)
 $\leq 400 \text{ mm}$ (for $n_{\text{CSB}} = 3$)
 $\leq 300 \text{ mm}$ (for $n_{\text{CSB}} \geq 4$)
- Number of tension bars per one-meter element n_{TB} : ≥ 2 (for $h \leq 300 \text{ mm}$)
 ≥ 4 (for $h \leq 500 \text{ mm}$)
- Diameter of the tension bars $\varnothing_{s,1}$: $\leq 20 \text{ mm}$
- Concrete cover of tension bars $c_{\text{nom},s}$: $\geq 30 \text{ mm}$
- Axial distance of the tension bars to the lateral component edge: $\geq 50 \text{ mm}$
- Axial distance of the tension bars: $\leq 600 \text{ mm}$ (for $n_{\text{TB}} = 2$)
 $\leq 400 \text{ mm}$ (for $n_{\text{TB}} = 3$)
 $\leq 300 \text{ mm}$ (for $n_{\text{TB}} \geq 4$)

Additional for HIT -HP/SP MVX (-OD, -OU) – Height offset

- Embedment depth of anchor heads: $\geq 145 \text{ mm}$
- Concrete cover of anchor heads to the axis of the bar: $\geq 60 \text{ mm}$
- Concrete cover of anchor heads to the lateral component edge: $\geq 60 \text{ mm}$
- Mandrel diameter of headed tension bars: $\geq 4 \varnothing_{s,1}$
- Minimum transverse reinforcement (fourth bar): $\geq 12 \text{ mm}$, direct at anchor head, see figure 3
- Minimum link reinforcement: $n_l \geq n_{\text{TB}} + 1$ with $A_l \geq \pi/4 * \varnothing_{s,1} * (n_{\text{TB}} + 1)$
- diameter of headed tension bars $\varnothing_{s,1}$: $\leq 12 \text{ mm}$
- Number of headed tension bars per one-meter element: ≥ 2 (for $h \leq 300 \text{ mm}$)
 ≥ 4 (for $h \leq 500 \text{ mm}$)
 ≤ 12
- Diameter of anchor head: $\geq 3 \varnothing_{s,1}$

Halfen Insulated Connection HIT-HP/SP

Annex A7

Product description
Dimensions

HIT-HP/SP ZVX (ZDX)

- Element height h : $160 \text{ mm} \leq h \leq 500 \text{ mm}$
- Number of compression shear bearings per one-meter element n_{CSB} : ≥ 2
 ≤ 12
- Concrete cover of the compression shear bearings c_{CSB} : $\geq 15 \text{ mm}$
- Axial distance of the compression shear bearings to the lateral component edge: $\geq 80 \text{ mm}$
- Axial distance of the compression shear bearings: $\geq 75 \text{ mm}$
- Number of shear bars per one-meter element n_{SB} : ≥ 2 (for $\varnothing_{\text{SB}} \leq 8 \text{ mm}$)
 ≥ 4 (for $\varnothing_{\text{SB}} > 8 \text{ mm}$)
- Diameter of the shear bars \varnothing_{SB} : $\leq 12 \text{ mm}$
- Bending diameter of shear bars: $\geq 6 \cdot \varnothing_{\text{SB}}$
- Axial distance of the shear bars to the lateral component edge: $\geq 6 \cdot \varnothing_{\text{SB}}$
- Axial distance of the shear bars: $\geq 6 \cdot \varnothing_{\text{SB}}$ (average) and
 $\geq 4 \cdot \varnothing_{\text{SB}}$ (minimum)
- Angle of the shear bars: $30^\circ \leq \alpha_{\text{SB}} \leq 60^\circ$
- Vertical offset between the shear bars and longitudinal reinforcement: $s_{\text{SB}} \leq 100 \text{ mm}$

Halfen Insulated Connection HIT-HP/SP

Annex A8

Product description
Dimensions

HIT-HP/SP DD (HIT-HP/SP AT; HIT-HP/SP FT analogues)

- Element height h : $160 \text{ mm} \leq h \leq 500 \text{ mm}$
- Number of tension and compression bars per one-meter element: ≥ 4
- Diameter of the tension and compression bars $\varnothing_{s,1}$: $\leq 20 \text{ mm}$
- Concrete cover of tension and compression bars $c_{\text{nom},o}$ resp. $c_{\text{nom},u}$: $\geq 30 \text{ mm}$
- Axial distance of the tension and compression bars to the lateral component edge: $\geq 50 \text{ mm}$
- Axial distance of the tension and compression bars: $\leq 300 \text{ mm}$
- Number of shear bars per one-meter element n_{SB} : ≥ 2 (for $\varnothing_{\text{SB}} \leq 8 \text{ mm}$)
 ≥ 4 (for $\varnothing_{\text{SB}} > 8 \text{ mm}$)
- Diameter of the shear bars \varnothing_{SB} : $\leq 12 \text{ mm}$
- Bending diameter of shear bars: $\geq 6 \cdot \varnothing_{\text{SB}}$
- Axial distance of the shear bars to the lateral component edge: $\geq 6 \cdot \varnothing_{\text{SB}}$
- Axial distance of the shear bars: $\geq 6 \cdot \varnothing_{\text{SB}}$ (average) and
 $\geq 4 \cdot \varnothing_{\text{SB}}$ (minimum)
- Angle of the shear bars: $30^\circ \leq \alpha_{\text{SB}} \leq 60^\circ$
- Vertical offset between the shear bars and longitudinal reinforcement: $s_{\text{SB}} \leq 100 \text{ mm}$

HIT-HP/SP MVXL (HIT-HP/SP OTX analogues)

All structural conditions of HIT-HP/SP MVX and HIT-HP/SP ZVX are analogous valid for HIT-HP/SP MVXL.

Halfen Insulated Connection HIT-HP/SP

Annex A9

Product description
Dimensions

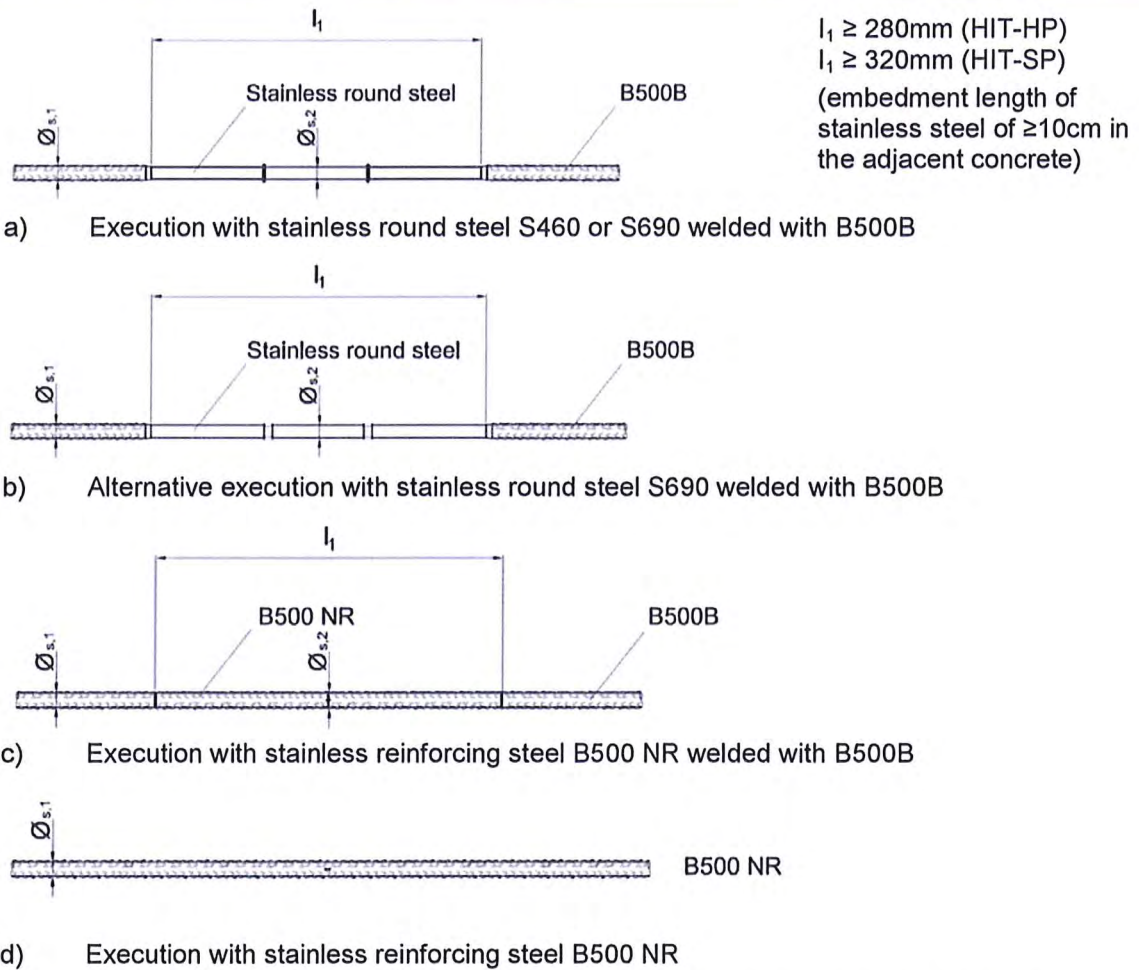

Figure 14: Tension/compression bar variations Halfen Insulated Connection HIT-HP/SP

$\varnothing_{s,1}$ (B500B, B500 NR)	$\varnothing_{s,2}$ (stainless round steel S690)	$\varnothing_{s,2}$ (stainless round steel S 460, B500 NR)
6 mm	-	6 mm
8 mm	≥ 7 mm	8 mm
10 mm	$\geq 8,5$ mm	10 mm
12 mm	$\geq 10,5$ mm*	12 mm
14 mm	-	14 mm
16 mm	-	16 mm
20 mm	-	20 mm

* at minimum 9,5mm at both notches with maximum length of 6mm (see Figure 14b)

Table A.1 Diameter combinations of HIT-HP/SP tension/compression bars

Halfen Insulated Connection HIT-HP/SP	Annex A10
Product description tension/compression bar variations	

The height offset tensions bars are executed with headed anchors on one side.

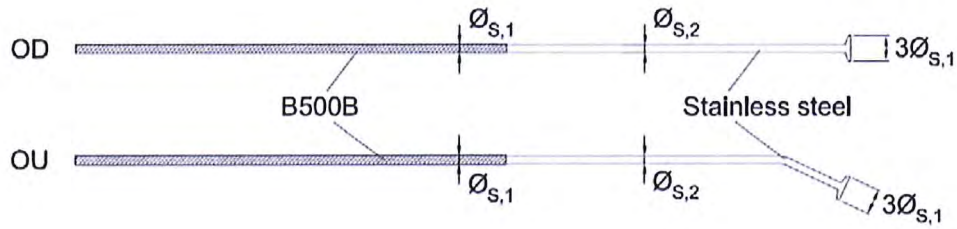
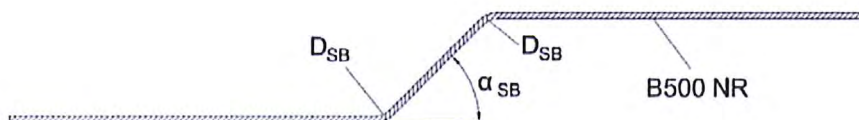

Figure 15: Tension bar variations Halfen Insulated Connection HIT-HP/SP MVX OU/OD (embedment length of stainless steel of $\geq 10\text{cm}$ in the adjacent concrete)

Halfen Insulated Connection HIT-HP/SP

Annex A11

Product description
tension/compression bar variations



a) Execution with stainless reinforcing steel B500 NR

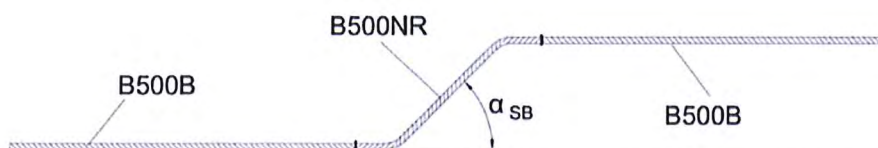

b) Execution with stainless reinforcing steel B500 NR in combination with B500B
(embedment length of B500 NR of ≥ 10 cm in the adjacent concrete)



c) Execution with stainless reinforcing steel B500 NR, upper leg of shear bar carried out as loop

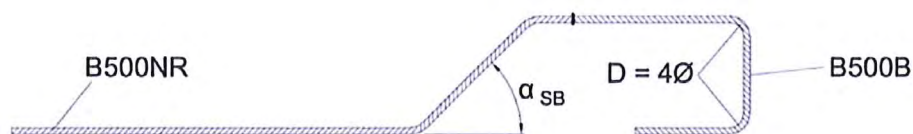

d) Execution with stainless reinforcing steel B500 NR, upper leg of shear bar carried out as loop
made of B500B
(embedment length of B500 NR of ≥ 10 cm in the adjacent concrete)

Figure 16: Shear bar variations Halfen Insulated Connection HIT-HP/SP

\varnothing_{SB} (B500B, B500 NR)	D_{SB} bending diameter	α_{SB} [°]
6 mm	6 \varnothing_{SB}	30 - 60
8 mm		
10 mm		
12 mm		

Table A.2 Execution variations HIT-HP/SP-Shear bars

Halfen Insulated Connection HIT-HP/SP		Annex A12
Product description shear bar variations		

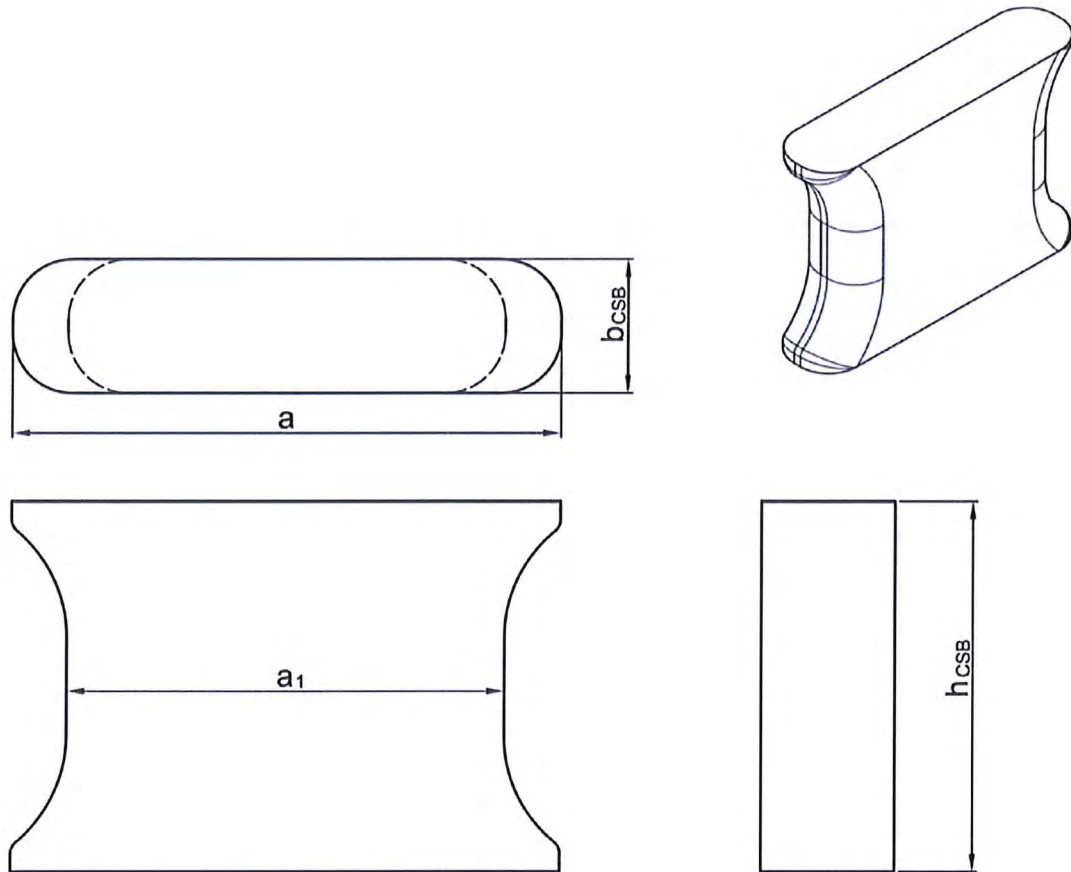

Figure 17: Double-symmetric compression shear bearing (CSB)

element type	HIT-HP	HIT-SP
h_{CSB}	83mm	83mm
b_{CSB}	30mm	30mm
a	123,6mm	163,6mm
a_1	98,6mm	138,6mm

Table A.3 Dimensions of HIT-HP/SP- CSB

Halfen Insulated Connection HIT-HP/SP

Annex A13

Product description
Double symmetric compression shear bearing

A.3 Materials

stainless steel:	B500 NR or stainless round steel (S460, S690) with corrosion resistance class III according to EN 1993-1-4, class A1 according to EN 13501-1
reinforcing steel:	B500B, class A1 according to EN 13501-1
compression shear bearings:	ultra high fibre-reinforced mortar, class A1 according to EN 13501-1
insulation joint:	thermal insulating fire protection material, mineral wool, class A1 according to EN 13501-1
plastic cover :	plastic material, performance as per EN 13501-1 is not determined

Halfen Insulated Connection HIT-HP/SP

Annex A14

Product description
Materials

B.1 Intended use

As external slabs also vertical members like balustrades or parapets can be connected with the product too. The forces are transmitted to the adjacent components by bond and surface pressure, respectively.

In particular the product is intended to be used:

- To minimise thermal bridges in buildings,
- To transfer static and quasi static bending moments, tension, compression and/or shear forces,
- For fire protection,
- Minimum concrete strength class of slabs made of reinforced normalweight concrete according to EN 206-1 is C20/25 (for internal components) and C25/30 (for external components).
- elements are applicable for slab heights between 160 to 500mm.

B.1.1 Design

EN 1992-1-1 in connection with EN 1993-1-1 and the provisions in accordance to Annex D shall apply to design.

- The connected slab shall be divided by joints which are installed in order to reduce the thermal stress in accordance with section B.2.1
- the static verification of the transfer of the transmitted loads shall be performed. The verification of the force transmission between the HIT-HP/SP elements and adjacent concrete shall be performed according to Annex D.
- strain state deviating from a monolithic concrete construction is limited to the joint area as well as to the adjacent edges when load bearing thermal insulation elements are used.
- At a distance h from the joint edge the undisturbed strain state may be assumed.
- Variable moments and shear forces along a connected edge shall be taken into account in the structural analysis.
- The slab connections are not suited for the locally limited transfer of torsional moments which are required to create the balance.
- Small normal forces due to imposed deformation in the girder bars (related to the strut-and-tie model) which occur at the end of the line supports e. g. next to free edges or expansion joints shall be neglected in the calculation. Normal constraining forces in the direction of the bars of the slab connection shall be eliminated (example see Annex B2).
- If the slabs connected to the load bearing thermal insulation elements are implemented as precast elements, an in-situ concrete stripe with a width of at least 10 cm according to Annex B6 to B8 shall be carried out between the load bearing thermal insulation elements and the precast concrete slab.
- The height-to-length ratio of the adjacent components should not exceed the ratio $1/3$, unless a separate verification of the transfer of the occurring transverse tensile stresses is made.
- Cutting the elements to size is allowed. The conditions due to Annex A7 – A9 have to be fulfilled after cutting. Elements must be protected against systematic moisture during storage, installation and assembling.

Halfen Insulated Connection HIT-HP/SP

Annex B1

Intended use
Design

B.2 Installation requirements

B.2.1 Joint distances

To limit the thermal stress expansion joints shall be installed perpendicular to the insulating layer in the external concrete components (see Figure 18). The joint distances are listed in table B.1.

joint thickness	Diameter of the tension bar in the joint [mm]					
	≤ 10,5	11	12	14	16	20
HIT-HP	13,5	12,2	11,7	10,1	9,2	8,0
HIT-SP	23,0	20,6	19,8	17,0	15,5	13,5

Table B.1 Joint distances s_{joint} [m]

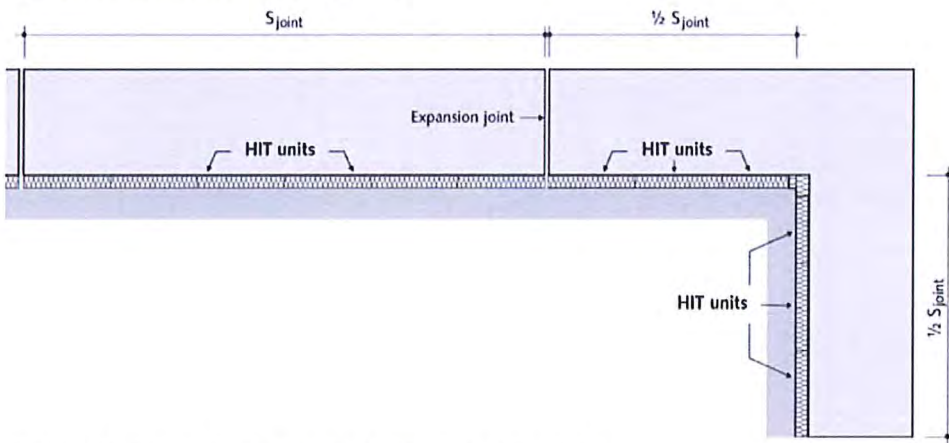

Figure 18: Installation situation with expansion joint

B.2.2 Structural Design

The minimum concrete cover according to EN 1992-1-1 shall be observed. This applies to the tension/compression bars, shear bars or to existing reinforcement.

The reinforcement of the concrete structure connected to the load bearing thermal insulation elements shall be extended to the insulating layer considering the required concrete cover according to EN 1992-1-1.

The transverse bars of the upper connecting reinforcement shall generally lie on top of the longitudinal bars of the slab connections. In case of bars with a nominal diameter smaller than 16 mm, under the respective existing in-situ conditions, the transverse bars can also be installed directly underneath the longitudinal bars of the slab connections and if this is monitored e. g. by the construction engineer. The corresponding required installation steps shall be specified in the installation manual (see Annexes B3 to B5).

The front surfaces of the components to be connected shall receive edge reinforcement according to EN 1992-1-1, chapter 9.3.1.4. U-bars $\varnothing \geq 6\text{mm}$, $s \leq 25\text{cm}$ and 2 longitudinal bars $\varnothing \geq 8\text{mm}$ shall be positioned on the front surface of the connected slabs parallel to the insulating joint. Lattice girders with a maximum space of 100mm to the insulating joint can be taken into account. A subsequent bending of the bars of the thermal insulation element is not permitted.

Halfen Insulated Connection HIT-HP/SP

Annex B2

Intended use
Installation requirements

Installation diagram

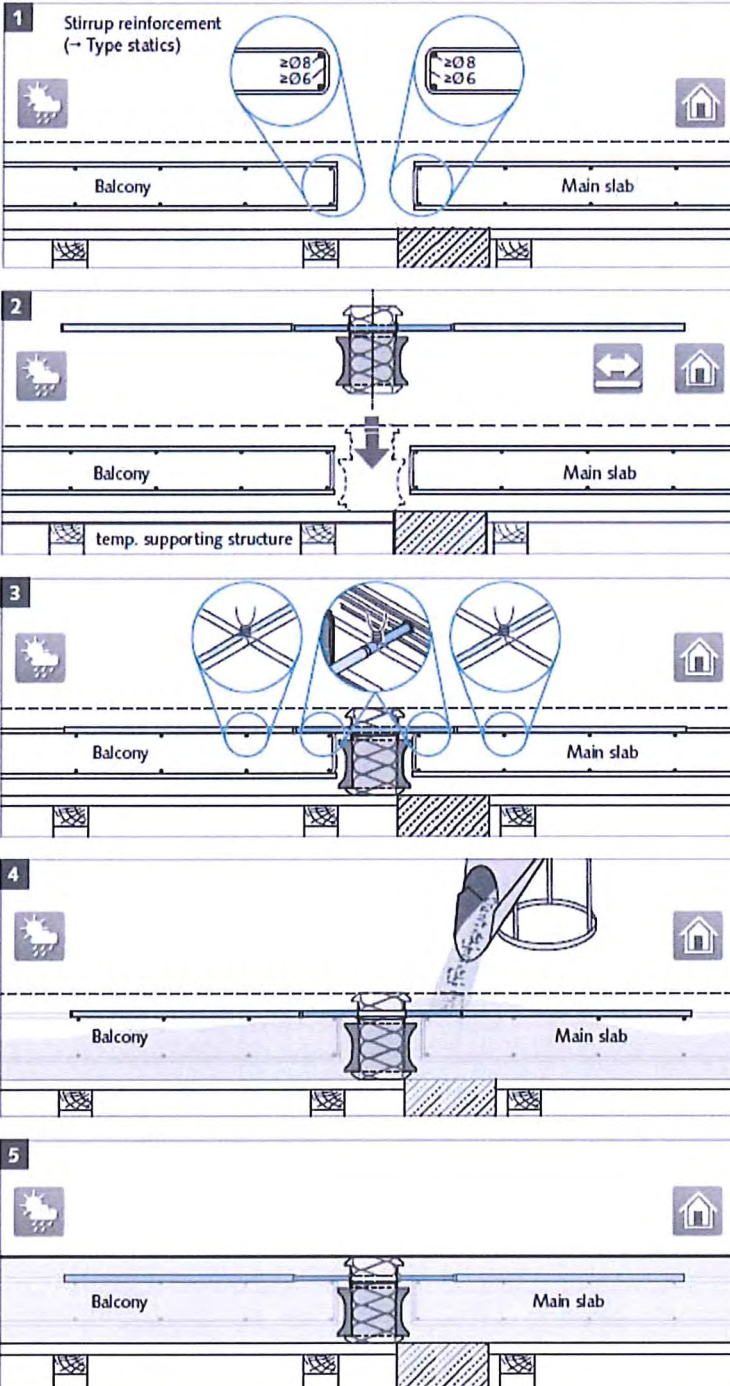

1 Installation of on-site reinforcement

The on-site reinforcement must be placed as specified by the structural engineer.

2 Installation of the HIT Element from above

The HIT-MVX Element is symmetrical; therefore, both installation directions are correct (custom solutions may vary).

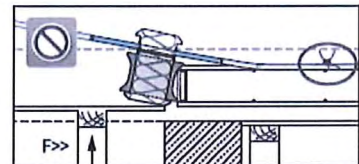
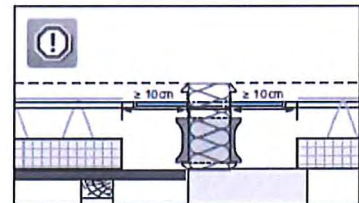

Ensure that the formwork is at the correct height!

3 Fix the HIT Tension bars to on-site reinforcement using tying wire

4 Pour the concrete

To ensure the HIT Elements are not displaced, pour and compact the concrete evenly. Secure the HIT Elements against movement.

5 Freshly concreted balcony slab on supporting structure

For further installation instructions please go to www.halfen.com.

Halfen Insulated Connection HIT-HP/SP

Annex B3

Intended use
Installation manual Type HIT-MVX

Installation diagram

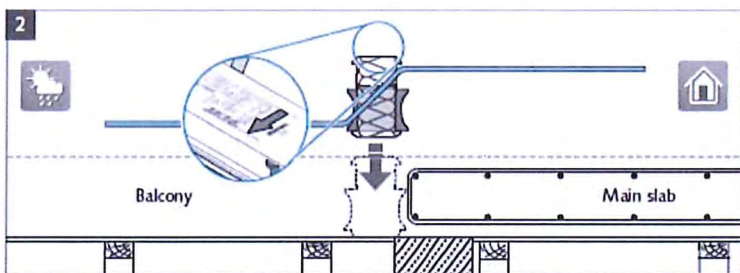
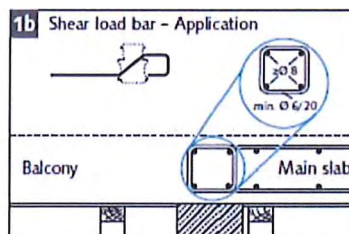
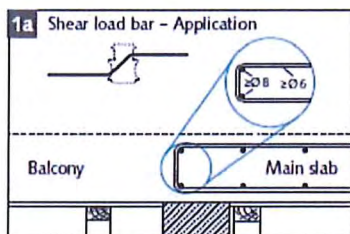

1 Installation of on-site reinforcement for the main slab

⚠ On-site reinforcement as specified by the structural engineer.

2 Installation of HIT Elements from above
HIT-ZDX Elements with bar diameters of $\phi 8$, 10 or 12 are symmetrical and do not have a dedicated installation direction.

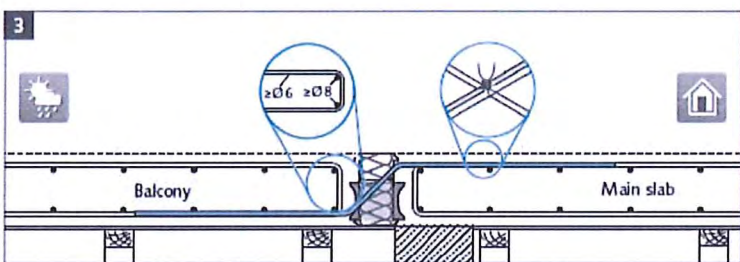
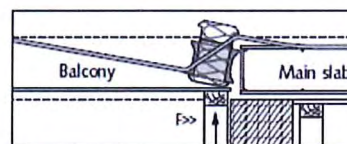

⚠ Ensure that the formwork is at the correct height!

3 Installation of the on-site reinforcement, balcony side
Fixing of the shear bars to on-site reinforcement using tying wire.

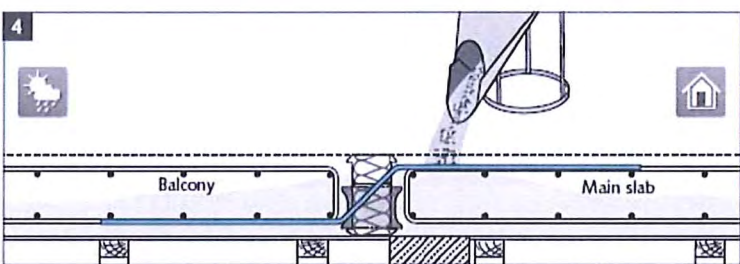

4 Pouring the concrete

⚠ To ensure the HIT Elements are not displaced, pour and compact the concrete evenly.

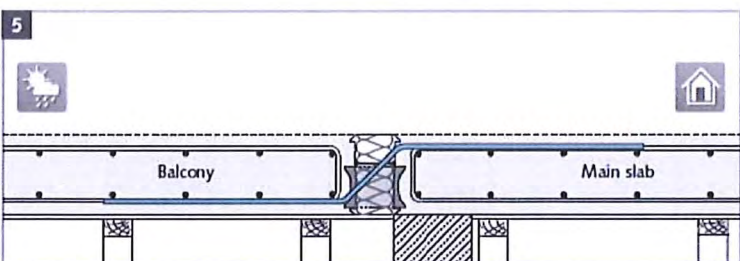

5 Freshly poured concrete balcony slab on support structure

ℹ Further installation diagrams for the types HIT-HP/SP ZVX and HIT-HP/SP ZDX can be found in the installation instructions – available for download at our website www.halfen.com.

Halfen Insulated Connection HIT-HP/SP

Annex B4

Intended use
Installation manual Type HIT-ZVX

Installation diagram

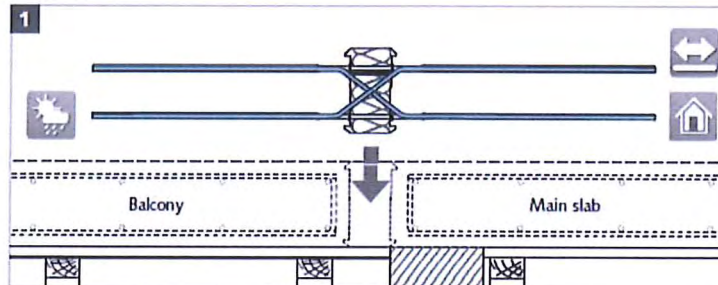

1 Positioning the HIT Element from above

The HIT-DD Element is symmetrical; therefore both installation directions are correct

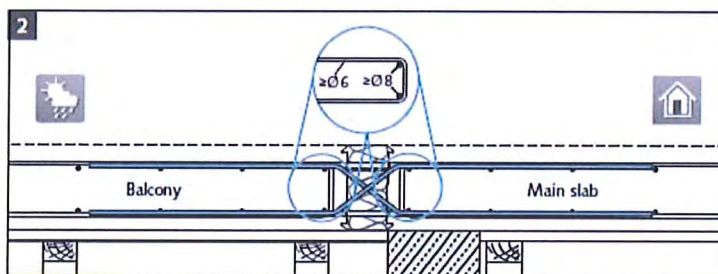

2 Installing on-site reinforcement

The on-site reinforcement must be placed as specified by the structural engineer

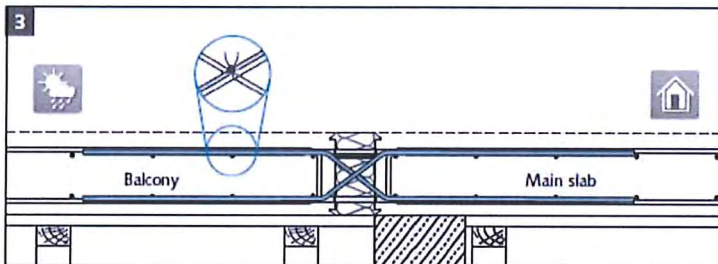

3 Fixing the tension bars and the shear bars to on-site reinforcement using tying wire

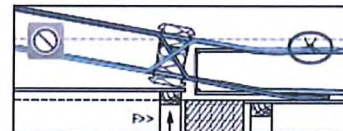

Ensure the formwork is at the correct height!

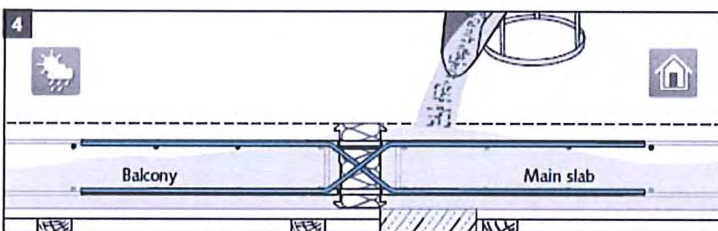

4 Pour the concrete

To ensure the HIT Elements are securely installed, pour and compact the concrete evenly. Ensure all HIT Elements are securely fixed.

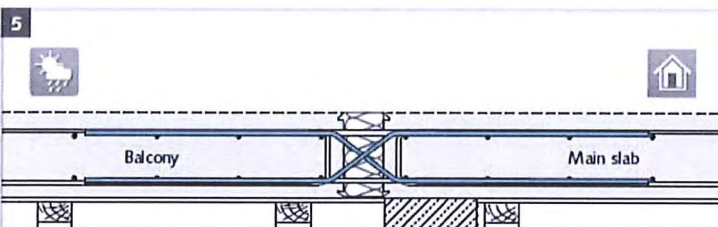

5 Freshly concreted balcony slab on supporting structure

For further installation instructions please visit www.halfen.com.

Halfen Insulated Connection HIT-HP/SP

Annex B5

Intended use
Installation manual Type HIT-DD

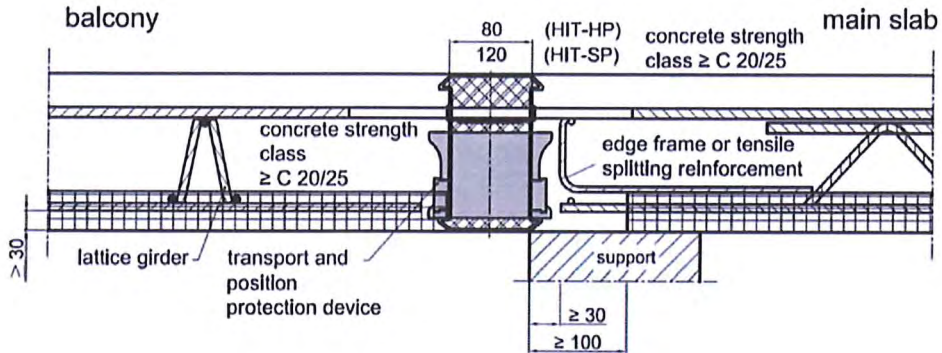

Figure 19: Example of the connection HIT-HP/SP MVX to element slabs with statically effective in-situ layer

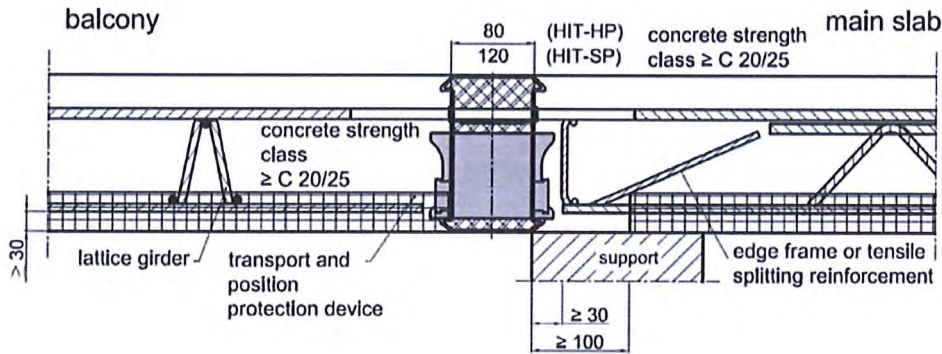

Figure 20: Example of the connection HIT-HP/SP MVX to element slabs with statically effective in-situ layer

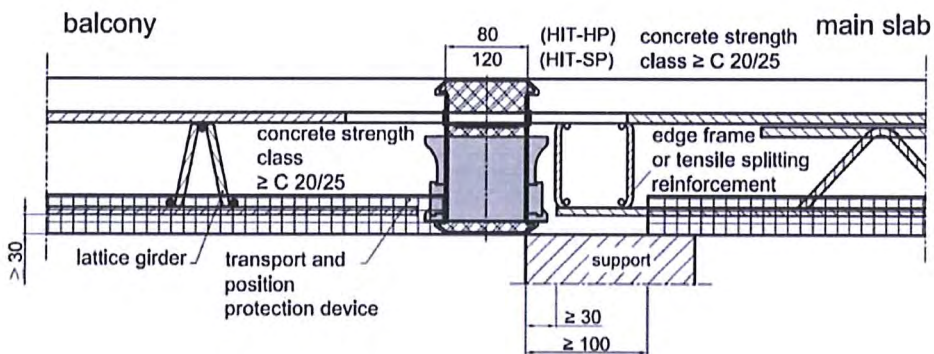

Figure 21: Example of the connection HIT-HP/SP MVX to element slabs with statically effective in-situ layer

Halfen Insulated Connection HIT-HP/SP

Annex B6

Intended use
Connection of precast concrete

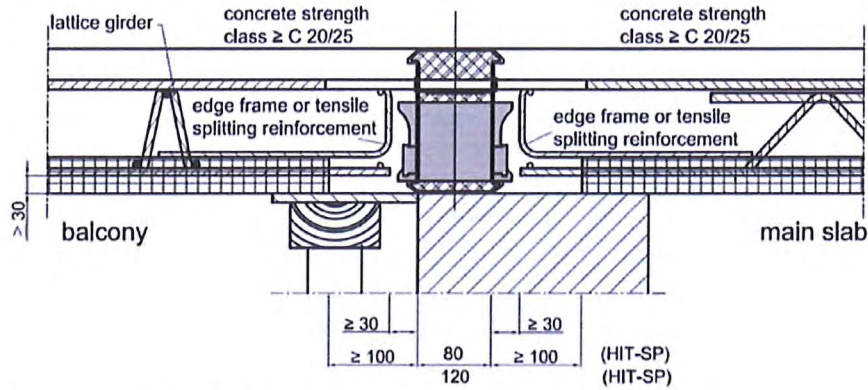

Figure 22: Example of the connection HIT-HP/SP MVX to element slabs with statically effective in-situ layer

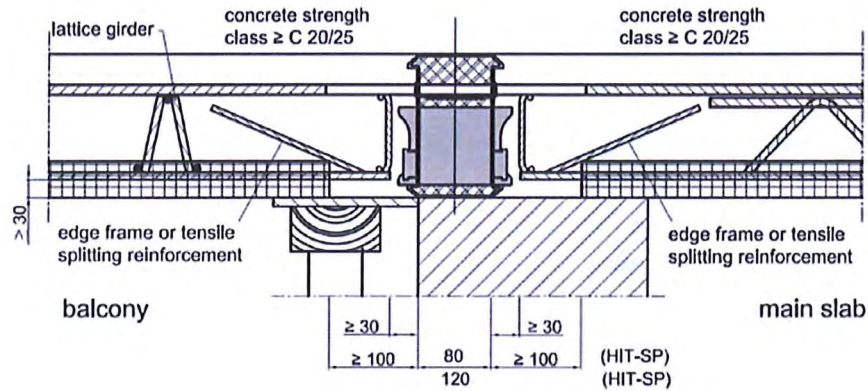

Figure 23: Example of the connection HIT-HP/SP MVX to element slabs with statically effective in-situ layer

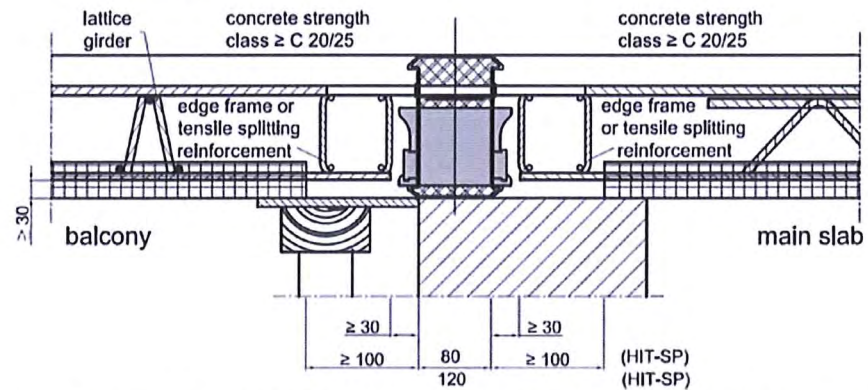

Figure 24: Example of the connection HIT-HP/SP MVX to element slabs with statically effective in-situ layer

Halfen Insulated Connection HIT-HP/SP

Annex B7

Intended use
Connection of precast concrete

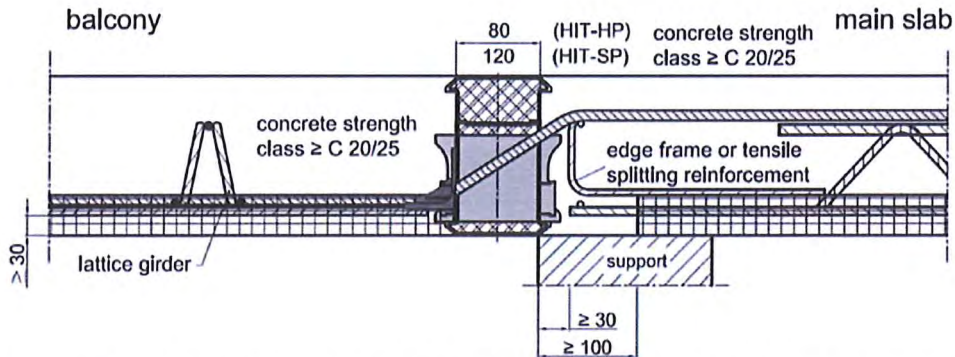

Figure 25: Example of the connection HIT-HP/SP ZVX to element slabs with statically effective in-situ layer

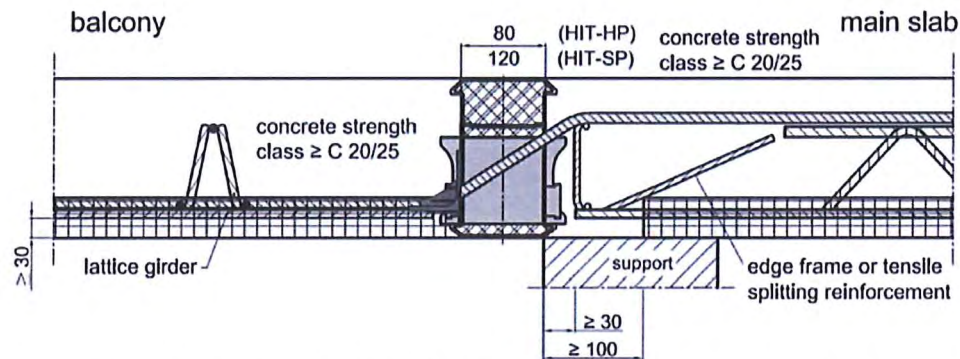

Figure 26: Example of the connection HIT-HP/SP ZVX to element slabs with statically effective in-situ layer

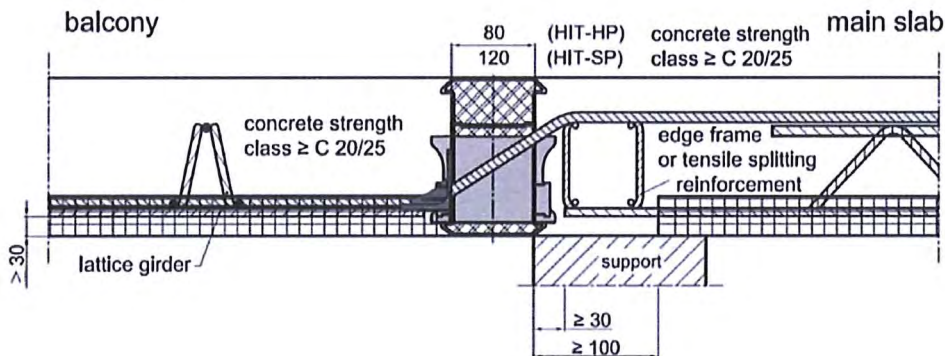

Figure 27: Example of the connection HIT-HP/SP ZVX to element slabs with statically effective in-situ layer

Halfen Insulated Connection HIT-HP/SP

Annex B8

Intended use
Connection of precast concrete

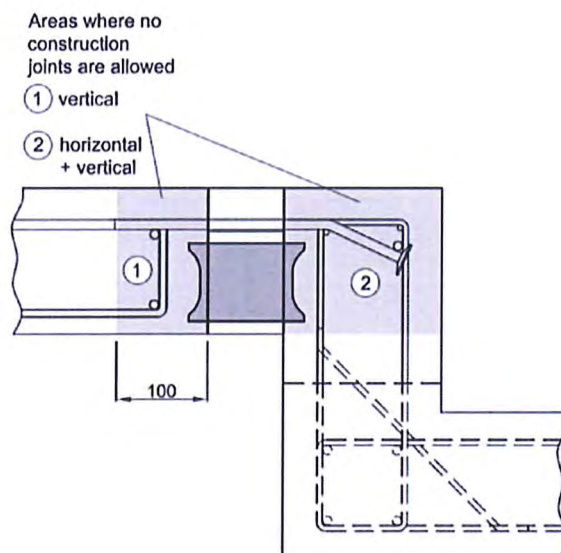

Figure 28: Reinforcement layout for height offset HIT-HP/SP MVX_OU

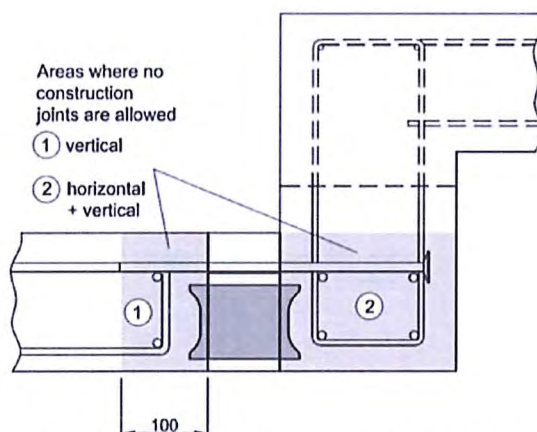

Figure 29: Reinforcement layout for Height offset HIT-HP/SP MVX_OD

Halfen Insulated Connection HIT-HP/SP

Annex B9

Intended use

Reinforcement layout for HIT-MVX_OU/OD

C.1 Load bearing capacity

C.1.1 Load bearing capacity of the bars in use

Bars made from	f_{yd} [N/mm ²]
B500B	435
B500 NR	435
Stainless round steel S460	418
Stainless round steel S690	627

Table C.1 Design values of the yield strength for tension loads

Diameter bar [mm]	Material [-]	$F_{sR,d}$ [kN]
8	B500NR	19,0
10	B500NR	34,1
12	B500NR	49,2
10,5	S690	49,2

Table C.2 Design values of the buckling loads of compression steel bars

C.1.2 Design value of the transferable forces

$$V_{CSB,d} \leq 18.200 \text{ N}$$

To determine the maximum load capacities M_{Rd} and V_{Rd} , M_{Ed} and V_{Ed} must be increased until one of the proofs becomes decisive.

M_{Ed} and V_{Ed} combinations according to

- Annex D3-D5 (HIT-MVX)
- Annex D6-D7 (HIT-MVXL) (HIT-OTX analogues)
- Annex D8-D9 (HIT-ZVX (ZDX))
- Annex D10 (HIT-DD) (HIT-AT, HIT-FT analogues).

C.1.3 Bearing design resistance

$F_{c,Rd}$ according to

- Annex D5 (HIT-MVX)
- Annex D7 (HIT-MVXL) (HIT-OTX analogues)
- Annex D9 (HIT-ZVX (ZDX)).

Halfen Insulated Connection HIT-HP/SP

Annex C1

Performance parameter
Load-bearing capacity

C.2 Fire resistance

C.2.1 Performance features regarding load bearing capacity in case of fire

If the performance characteristics specified in Annex C1 for verification according to the intended use under normal temperatures are met, the load bearing capacity of connections with HALFEN HIT-HP/SP is also guaranteed in case of fire for the fire resistance period 120 minutes for design variants according to Figures (see Annex A1 to A5). This applies to a reduction coefficient η_{fi} according to EN 1992-1-2, section 2.4.2 to $\eta_{fi} = 0,7$.

Halfen Insulated Connection HIT-HP/SP

Annex C2

Performance parameter
Load-bearing capacity in case of fire

C.2.2 Resistance to fire of building elements (informative)

Floor or roof structures as well as balcony and walkways connected to reinforced concrete components with HALFEN HIT-HP/SP as far the intended use can be classified as specified in Table C.3 in terms of fire resistance in accordance with EN 13501-2. The following boundary conditions must be observed:

- The load bearing capacity on case of fire has been declared for Halfen Insulated Connection HIT-HP/SP.
- Connections of the remaining edges of floor or roof structures, which are not connected with the Halfen Insulated Connection HIT-HP/SP to adjacent or supporting components, shall be verified in accordance with the provisions of the member states for the corresponding fire resistance.

Design variant according to	Floor or roof construction wires fire separating function	Balcony and walkway
Annex A1 to A5	REI 120	R120

Table C.3 Component classification

Halfen Insulated Connection HIT-HP/SP	Annex C3
Classification of building elements (informative) Fire resistance	

C.3 Thermal resistance

Thermal resistance shall be calculated according to EN ISO 6946 and EN ISO 10211. The equivalent thermal resistance of thermal insulation element $R_{eq, TI}$ shall be determined by using numerical methods (e.g. finite element method) and a detailed 3D model of the thermal insulation element for the configuration shown in figure 30. As an alternative to these simplified models, detailed models can also be used. The nominal thickness $d_{n, TI}$ of the thermal insulation element shall be determined and all indentations as well as all protrusions shall be taken into account.

$$R_{cal} = R_{eq, TI} + R_{con}$$

$$R_{eq, TI} = R_{cal} - R_{con} = R_{cal} - \frac{0,06m}{2,3 W/(mK)}$$

$$\lambda_{eq, TI} = \frac{d_{n, TI}}{R_{eq, TI}}$$

Where: $d_{n, TI}$ nominal thickness of thermal insulation element
 $\lambda_{eq, TI}$ equivalent thermal conductivity of thermal insulation element
 R_{cal} calculated thermal resistance for configuration
 R_{con} thermal resistance of concrete
 $R_{eq, TI}$ equivalent thermal resistance of thermal insulation element

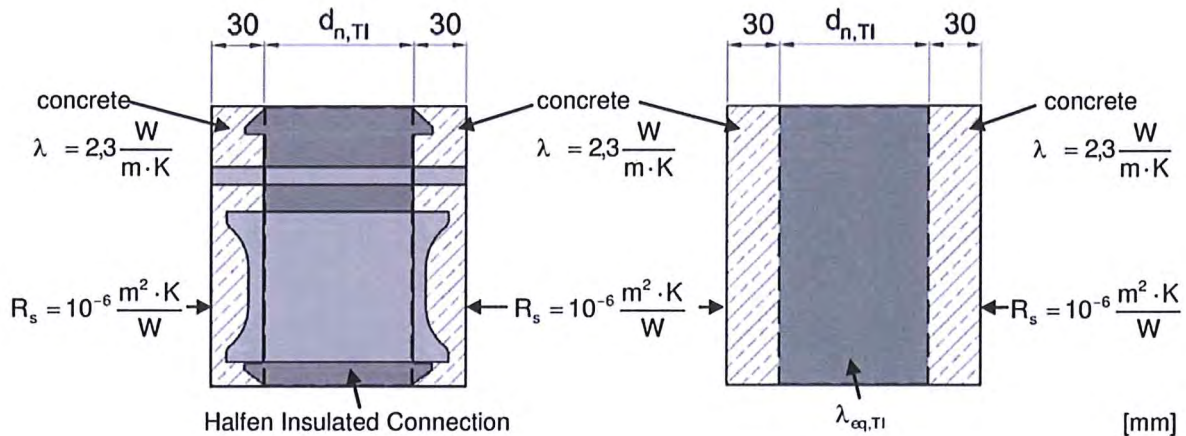

Figure 30: Cross section of configuration to calculate the equivalent thermal resistance $R_{eq, TI}$ and simplified analogous model

Halben Insulated Connection HIT-HP/SP	Annex C4
Performance parameters Thermal resistance	

As an alternative to the using numerical methods the following simplify equation can be used.

$$\lambda_{eq, TI} = C_{eq} \cdot \sum_i \frac{A_i \cdot \lambda_i}{B_{HIT} \cdot H_{HIT}}$$

Where: C_{eq} correction coefficient according to table C.4
 A_i cross section of the layer i according to table C.5
 λ_i thermal conductivity of the layer i according to table C.5
 B_{HIT} width of the HIT element
 H_{HIT} height of the HIT element

HIT type	HIT-MVX	HIT-ZVX	HIT-ZDX	HIT-DD	HIT-MVXL
C_{eq}	0,84	0,79	0,73	0,83	0,84

Table C.4 Correction coefficient C_{eq} for wall constructions according to Figure 31

i	Layer	material	A_i	λ_i	According to
				[W/(mK)]	
1	tension bar	Stainless steel	Cross section in the joint (A_{TB})	13 - 17	EN 10088-1
2	shear bar	Stainless steel	Cross section in the joint (A_{SB})	13 - 17	EN 10088-1
3	CSB	fibre-reinforced mortar	$A_{CSB} = n_{CSB} \cdot 24,9 \text{ cm}^2$	acc. to data sheet	EN 12664 and EN ISO 10456
4	cover	PVC-U	Horizontal cross section (A_{cover})	0,17	EN ISO 10456
5	insulation	Mineral wool	Cross section in the joint (A_{Mwo})	0,035	EN 13162 and EN ISO 10456

Table C.5 Design values of the thermal conductivity and other information of the different layers

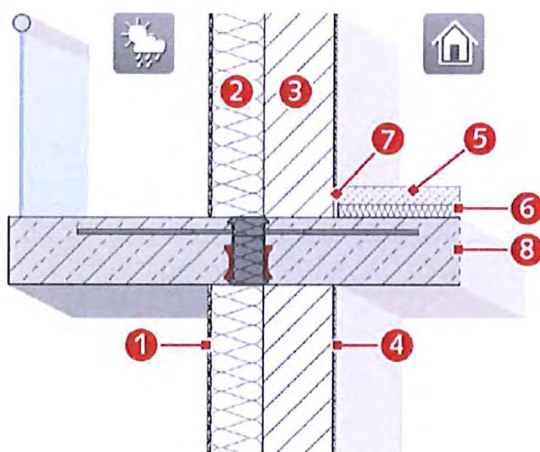

1	Plaster exterior
2	Insulation (120-300mm)
3	Bearing layer (150-350mm)
4	Plaster interior
5	Screed
6	Insulation
7	Edge insulation
8	Bearing layer ($\geq 160\text{mm}$)

Figure 31: Wall construction with ETICS

Halfen Insulated Connection HIT-HP/SP

Performance parameters
Thermal resistance

Annex C5

C.4 Impact sound insulation according to EN ISO 10140

HIT unit	Weighted normalized impact sound pressure level difference $\Delta L_{n,w}$ [dB]
HIT-HP MVX-0504-18-100-35	12
HIT-HP MVX-0705-18-100-35	11
HIT-HP MVX-1207-18-100-35	11
HIT-SP MVX-0504-18-100-35	14
HIT-SP MVX-0705-18-100-35	15
HIT-SP MVX-1208-18-100-35	10

Table C.6 Weighted normalized impact sound pressure level difference $\Delta L_{n,w}$ [dB] derived from laboratory tests

HIT unit	Weighted normalized impact sound pressure level difference $\Delta L_{n,w}$ [dB]
HIT-HP ZVX-0504-18-100-30-12	12
HIT-HP ZVX-0705-18-100-30-12	11
HIT-HP ZVX-1207-18-100-30-12	11
HIT-SP ZVX-0504-18-100-30-12	14
HIT-SP ZVX-0705-18-100-30-12	15
HIT-SP ZVX-1208-18-100-30-12	10

Table C.7 Weighted normalized impact sound pressure level difference $\Delta L_{n,w}$ [dB] derived from laboratory tests

Halfen Insulated Connection HIT-HP/SP	Annex C6
Performance parameters Impact sound insulation	

D.1 Structural analysis

D.1.1 Signs and Symbols

(units in [N] and [mm])

h	element height
b_{Unit}	width of Halfen Insulated Connection HIT-HP/SP
d	effective depth of the slab (floor and balcony)
n_{CSB}	number of compression shear bearings
h_{CSB}	height of compression shear bearings (= 83 [mm])
c_{CSB}	concrete cover of the CSB (=15 [mm])
$c_{nom,s}$	concrete cover of the tension bars
n_{TB}	number of tension bars
$\varnothing_{s,1}$	diameter of the tension/compression bars
$\varnothing_{s,2}$	diameter of the stainless steel part of the tension/compression bars
α_{SB}	Inclination of shear bar
\varnothing_{SB}	diameter of the shear bar
$c_{v,l}$	concrete cover of reinforcement of the slabs
$c_{nom,o}$	concrete cover of the bars at the top
$c_{nom,u}$	concrete cover of the bars at the bottom
f_{yd}	design value of the yield stress of the reinforcing steel

element type	HIT-HP	HIT-SP
t_{HIT}	80mm	120mm
l_1	280mm	320mm
a_{CSB}	110mm	150mm
a_{Rd}	140	122

Table D.1 Various Dimensions for HIT-HP and HIT-SP

element type	HIT-HP/SP	HIT-HP	HIT-SP
concrete compressive class	$\beta_{c1,M}$ [N/mm]	$\beta_{c2,V}$ [N/mm ²]	$\beta_{c2,V}$ [N/mm ²]
C20/25	800	14,5	10,7
≥ C25/30	945	17,2	12,6

Table D.2 Factors $\beta_{c1,M}$ and $\beta_{c2,V}$ for HIT-HP and HIT-SP

Halfen Insulated Connection HIT-HP/SP

Structural analysis
Signs and symbols

Annex D1

D.1.2 General

- Structural verification shall be performed for each individual case.
- Type-tested load tables may be used.
- The corrosion protection is ensured by compliance with the concrete cover of the on-site reinforcement according to EN 1992-1-1 and the use of the materials according to Annex A14
- Verification of the welded connection between reinforcement steel and stainless steel is not necessary.
- The shear force reinforcement required in the insulation layer does not determine the minimum slab thickness according to EN 1992-1-1, chapter 9.3.2 (1).
- Verification of the required bending diameter is fulfilled if the conditions according to Annex A7-A9 are met.
- The anchorage and lap length of the bars passing the insulation layer shall be verified in accordance with EN 1992-1-1.
- The verification of fatigue due to temperature difference is provided by the limitation of the joint distances according to Table B.1

Design of the on-site vertical reinforcement for the adjacent components

Structural vertical reinforcement

The front surfaces of the components to be connected shall at least receive edge reinforcement according to EN 1992-1-1, chapter 9.3.1.4 U-bars $\varnothing \geq 6\text{mm}$, $s \leq 25\text{cm}$ ($=A_{sV,min}$)

Vertical tensile splitting reinforcement

$$F_{Sp,v} = \frac{|F_{cd}|}{4} \cdot \left(1 - \frac{x_c}{x_c + c}\right)$$

With: F_{cd} , x_c according to Annex D4 (HIT-MVX)
Annex D6 (HIT-MVXL) (HIT-OTX analogues)
Annex D8 (HIT-ZVX (ZDX))

$$c = 30\text{mm}$$

$$A_{sV,Sp} = \frac{F_{Sp,v}}{f_{yd}}$$

Supporting reinforcement

Supporting reinforcement shall be designed for the entire shear force V_{Ed} .

$$A_{sV,s} = \frac{V_{Ed}}{f_{yd}}$$

D.1.3 Verification in the ultimate limit state

According to Annex D3-D5 (HIT-MVX)
Annex D6-D7 (HIT-MVXL) (HIT-OTX analogues)
Annex D8-D9 (HIT-ZVX (ZDX))
Annex D10 (HIT-DD) (HIT-AT, HIT-FT analogues)

Halfen Insulated Connection HIT-HP/SP		Annex D2
Structural analysis General		

D.1.3.1 HIT-HP/SP MVX

Strut-and-tie model of Halfen Insulated Connection HIT-HP/SP MVX (general)

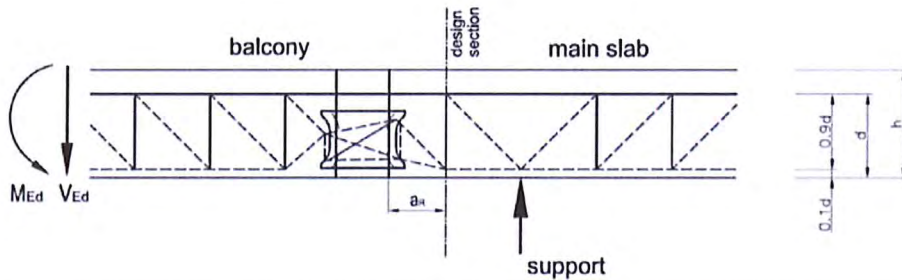

Figure 32: Strut-and-tie model and design section HIT-HP/SP MVX with compression shear bearing

Strut-and-tie model Halfen Insulated Connection HIT-HP/SP MVX-...-OD/-OU (Height offset)

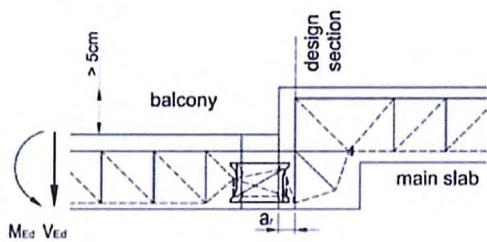

Figure 33: Strut-and-tie model HIT-HP/SP MVX-...-OD

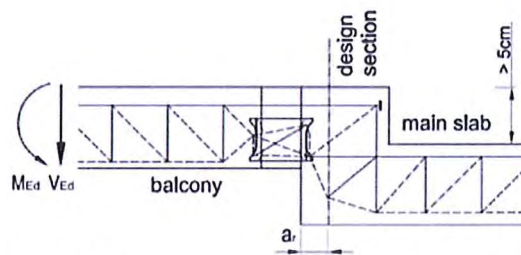

Figure 34: Strut-and-tie model HIT-HP/SP MVX-...-OU

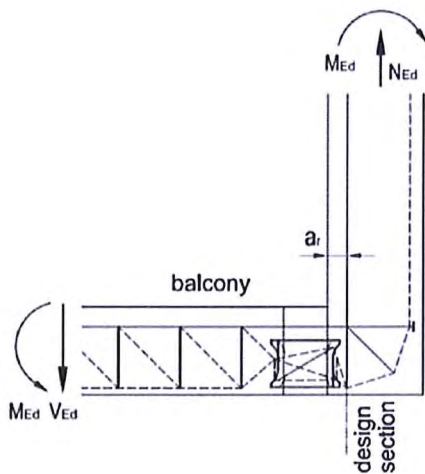

Figure 35: Strut-and-tie model HIT-HP/SP MVX-...-OD (wall connection)

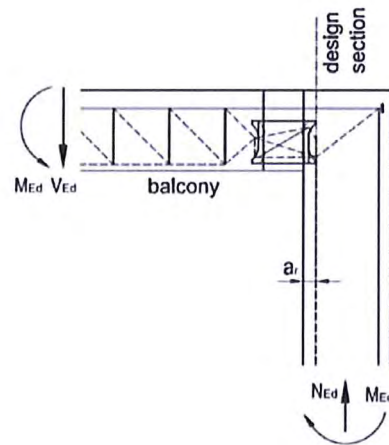

Figure 36: Strut-and-tie model HIT-HP/SP MVX-...-OU (wall connection)

Halfen Insulated Connection HIT-HP/SP

Annex D3

Structural analysis
HIT-HP/SP MVX

Distance between design section and component edge

$$a_r = 96 \text{ mm} - 0,1 \cdot d \quad (a_r \approx 80 \text{ mm})$$

In the ultimate limit state a ratio between bending moment M_{Ed} and shear force V_{Ed} of at least

$$\frac{M_{Ed}}{V_{Ed}} \geq 0,15 \text{ [m]} \text{ shall be adhered to.}$$

Determination of internal forces resulting from moment / shear force interaction

Concrete compression zone height of compression shear bearing:

$$x_c = \text{Max} \left\{ \begin{array}{l} d_{CSB} - \sqrt{(d_{CSB})^2 - \frac{|M_{Ed}|}{\beta_{c1,M} \cdot n_{CSB}}} \\ \frac{h_{CSB}}{2} - \sqrt{\left(\frac{h_{CSB}}{2}\right)^2 - \frac{|V_{Ed}|}{\beta_{c2,V} \cdot n_{CSB}}} \end{array} \right. \leq h_{CSB} \quad (\text{units in [N] and [mm]})$$

$$\text{where: } d_{CSB} = h - c_{nom,s} - \frac{d_{s,1}}{2} - c_{CSB}$$

Concrete compressive force F_{cd} (negative) und steel tensile force F_{sd} (positive):

$$-F_{cd} = F_{sd} = 2 \cdot x_c \cdot n_{CSB} \cdot \beta_{c1,M} \quad (\text{units in [N] and [mm]})$$

$$V_{Rd} = \text{Min} \left\{ \begin{array}{l} n_{CSB} \cdot V_{CSB,d} \\ |F_{cd}| \cdot \frac{(h_{CSB} - x_c)}{a_{CSB}} \end{array} \right.$$

$$\text{Verification:} \quad \text{Shear load: } |V_{Ed}| \leq V_{Rd}$$

Verification of required tension bar reinforcement:

$$A_{s,req} = \frac{F_{sd}}{f_{yd}}$$

Halfen Insulated Connection HIT-HP/SP

Annex D4

Structural analysis
HIT-HP/SP MVX

Verification of concrete edge failure

Actions in the design section:

$$F_{c,Ed} = 0,25 \cdot |F_{cd}| + |V_{Ed}|$$

Bearing resistance:

$$F_{c,Rd} = a_{Rd} \cdot (f_{ck})^{\frac{1}{4}} \cdot b_{eff} \cdot \psi_{BK}$$

where: $b_{eff} = n_{CSB} \cdot 137[\text{mm}] \leq b_{Unit}$

$$\psi_{BK} = 1,0 \quad \text{general}$$

$$\psi_{BK} = 0,7 \quad \text{applicable to HIT-HP/SP MVX-...-OD (Balcony offset downward, see Annex A1, Figure 2)}$$

Verification:

$$F_{c,Ed} \leq F_{c,Rd}$$

When designing the adjacent slabs, the following loads shall be considered:

Main slab: $M_{Ed,slab} = \text{Max} \begin{cases} M_{Ed} \\ F_{cd} \cdot z_1 \end{cases}$ in the design section

$$\text{where } z_1 = d - \frac{1}{2} \cdot x_c - c_{CSB}$$

Balcony slab: $M_{Ed,balcony} = M_{Ed,slab} - |V_{Ed}| \cdot a_{CSB}$

On-site vertical reinforcement at the front surfaces of the adjacent components

- moment and downward shear force:

- Balcony side: $A_{sV} = \text{Max} \begin{cases} A_{sV,min} \\ A_{sV,sp} \end{cases}$

- Main slab side: direct support $A_{sV,min}$
indirect support $A_{sV} = \text{Max} \begin{cases} A_{sV,min} \\ A_{sV,sp} + A_{sV,s} \end{cases}$

- moment and upward shear force:

- Balcony side: $A_{sV} = \text{Max} \begin{cases} A_{sV,min} \\ A_{sV,sp} + A_{sV,s} \end{cases}$

- Main slab side: direct support $A_{sV,min}$
indirect support $A_{sV} = \text{Max} \begin{cases} A_{sV,min} \\ A_{sV,sp} \end{cases}$

$A_{sV,min}$, $A_{sV,sp}$ and $A_{sV,s}$ according to Annex D2

Halfen Insulated Connection HIT-HP/SP

Annex D5

Structural analysis
HIT-HP/SP MVX

D.1.3.2 HIT-HP/SP MVXL

Strut-and-tie model of Halfen Insulated Connection HIT-HP/SP MVXL

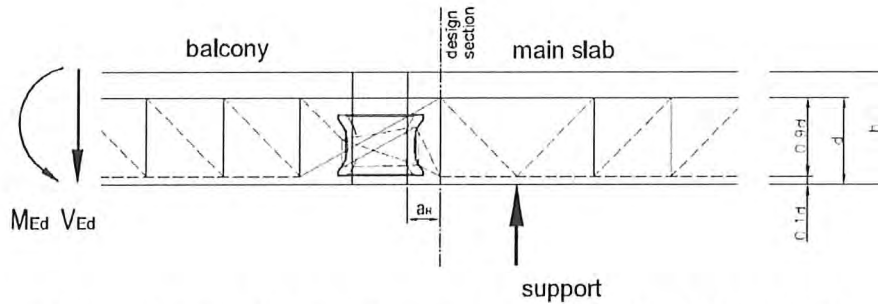

Figure 37: Strut-and-tie model and design section HIT-HP/SP MVXL with compression shear bearing

Determination of internal forces resulting from moment

Concrete compression zone height of compression shear bearing from moment:

$$x_{c,M} = (d - 15) - \sqrt{(d - 15)^2 - \frac{|M_{Ed}|}{n_{CSB} \cdot \beta_{c1,M}}} \leq 83 \text{ [mm]}$$

Concrete compressive force $F_{cd,M}$ (negativ) from moment

$$F_{cd,M} = -2 \cdot x_{c,M} \cdot n_{CSB} \cdot \beta_{c1,M} \quad (\text{units in [N] and [mm]})$$

$$F_{sd,M} = -(F_{cd,M} + F_{SB,Hd})$$

Determination of internal forces from shear force

Concrete compression zone height of compression shear bearing from shear force

(units in [N] and [mm])

$$x_{c,V} = \max \left\{ \frac{\frac{h_{CSB} + a_{CSB} \cdot \tan \alpha_{SB} \cdot \beta}{2} - \sqrt{\left(\frac{h_{CSB} + a_{CSB} \cdot \tan \alpha_{SB} \cdot \beta}{2} \right)^2 - \frac{|V_{Ed}|}{\beta_{c2,v} \cdot n_{CSB}}}{2 \cdot n_{CSB} \cdot \beta_{c1,M} \cdot \tan \alpha_{SB} \cdot \beta}, \frac{n_{CSB} \cdot V_{CSB,d}}{V_{Ed}} - \min \left\{ \frac{|F_{cd,M}| \cdot (h_{CSB} - x_{c,M})}{a_{CSB}} \right\} \right\} \leq 83 \text{ mm}$$

$$\beta = \left(1 + \frac{A_{TB,\varnothing_{s,2}}}{60 \text{ (mm}^2) \cdot n_{CSB}} \right) \quad \text{with: } A_{TB,\varnothing_{s,2}} = n_{TB} \cdot \frac{\pi}{4} \cdot \varnothing_{s,2}^2 \quad [\text{mm}^2]$$

Halfen Insulated Connection HIT-HP/SP

Annex D6

Structural analysis
HIT-HP/SP MVXL

Concrete compressive force $F_{cd,V}$ from shear force:

$$F_{cd,V} = -2 \cdot x_{c,V} \cdot n_{CSB} \cdot \beta_{c1,M} \quad (\text{units in [N] and [mm]})$$

$$F_{SB,Hd} = -(\beta \cdot F_{cd,V})$$

Verification of shear bar reinforcement:

$$A_{s,SB,erf} = \frac{F_{SB,d}}{f_{yd}} \quad \text{with: } F_{SB,d} = \frac{F_{SB,Hd}}{\cos \alpha_{SB}}$$

Verification of tension bar reinforcement:

$$A_{s,erf} = \frac{|F_{Sd,M}|}{f_{yd}} \quad \text{with: } F_{Sd,M} = -(F_{cd,M} + F_{SB,Hd})$$

Verification of concrete edge failure

Actions in the design section:

$$F_{C,Ed} = 0,25 \cdot |\max(F_{cd,M}; F_{cd,V})| + |V_{Ed,CSB}|$$

$$\text{with: } V_{Ed,CSB} = |F_{cd,V}| \cdot \frac{\max(41,5; 83 - x_{c,V})}{a_{CSB}}$$

bearing resistance:

$$F_{C,Rd} = a_{R,d} \cdot (f_{ck})^{\frac{1}{4}} \cdot b_{eff} \quad \text{with: } b_{eff} = n_{CSB} \cdot 137(\text{mm}) \leq b_{Element}$$

$$\text{verification: } F_{C,Ed} \leq F_{C,Rd}$$

When designing the adjacent slabs, the following loads shall be considered:

See Annex D4.

On-site vertical reinforcement at the front surfaces of the adjacent components

- Balcony side: $A_{sV} = \text{Max} \begin{cases} A_{sV,min} \\ A_{sV,sp} \end{cases}$
- Main slab side: direct support $A_{sV,min}$
- indirect support $A_{sV} = \text{Max} \begin{cases} A_{sV,min} \\ A_{sV,sp} + A_{sV,s} \end{cases}$

$A_{sV,min}$, $A_{sV,sp}$ and $A_{sV,s}$ according to Annex D2.

Halfen Insulated Connection HIT-HP/SP

Annex D7

Structural analysis
HIT-HP/SP MVXL

D.1.3.3 HIT-HP/SP ZVX (ZDX)

Strut-and-tie model of Halfen Insulated Connection HIT-HP/SP ZVX

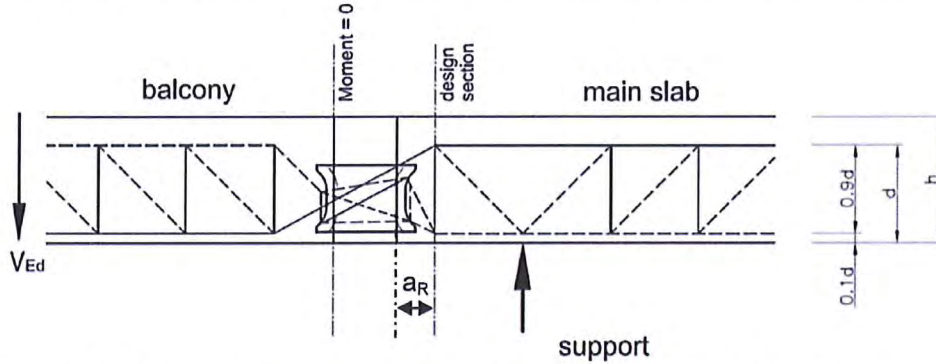

Figure 38: Strut-and-tie model and design section HIT-HP/SP ZVX with compression shear bearings (HIT-HP/SP ZDX analogue)

The design action V_{Ed} is to be calculated at the defined position of the joint (Moment = 0), the verification has to be performed at the design section.

Determination of internal force

Concrete compression zone height of compression shear bearings (units in [N] and [mm])

$$x_c = \text{Max} \left\{ \begin{array}{l} \left(\frac{h_{CSB} + a_{CSB} \cdot \tan \alpha_{SB}}{2} \right) - \sqrt{\left(\frac{h_{CSB} + a_{CSB} \cdot \tan \alpha_{SB}}{2} \right)^2 - \frac{|V_{Ed}|}{\beta_{c2,v} \cdot n_{CSB}}} \\ \frac{(V_{Ed} - n_{CSB} \cdot V_{CSB,d})}{2 \cdot n_{CSB} \cdot \beta_{c1,M} \cdot \tan \alpha_{SB}} \end{array} \right. \leq h_{CSB}$$

Verification of required shear bar reinforcement

$$A_S = \frac{F_{SB,d}}{f_{y,d}} \quad \text{with: } F_{SB,d} = \frac{-F_{cd}}{\cos \alpha_{SB}}$$

Verification of concrete edge failure

Actions in the design section:

$$F_{c,Ed} = 0,25 \cdot |F_{cd}| + |V_{Ed,CSB}|$$

$$V_{Ed,CSB} = F_{cd} \cdot \frac{\text{Max}(h_{CSB} - x_c; 0,5 \cdot h_{CSB})}{a_{CSB}}$$

Halfen Insulated Connection HIT-HP/SP

Annex D8

Structural analysis
HIT-HP/SP ZVX (ZDX)

Bearing resistance:

$$F_{c,Rd} = a_{Rd} \cdot (f_{ck})^{\frac{1}{4}} \cdot b_{eff} \quad (\text{units in [N] and [mm]})$$

with: $b_{eff} = n_{CSB} \cdot 137[\text{mm}] \leq b_{Unit}$

Verification:

$$F_{c,Ed} \leq F_{c,Rd}$$

Additional design force for the verification of the main slab (moment of displacement)

$$M_{Ed,Decke} = V_{Ed} \cdot t_{HIT}$$

On-site vertical reinforcement at the front surfaces of the adjacent components

HIT-ZVX

- Balcony side: $A_{sV} = \text{Max} \begin{cases} A_{sV,min} \\ A_{sV,sp} \end{cases}$
- Main slab side: direct support $A_{sV,min}$
- indirect support $A_{sV} = \text{Max} \begin{cases} A_{sV,min} \\ A_{sV,sp} + A_{sV,s} \end{cases}$

HIT-ZDX

- Balcony side: $A_{sV} = \text{Max} \begin{cases} A_{sV,min} \\ A_{sV,sp} + A_{sV,s} \end{cases}$
- Main slab side: direct support $A_{sV,min}$
- indirect support $A_{sV} = \text{Max} \begin{cases} A_{sV,min} \\ A_{sV,sp} + A_{sV,s} \end{cases}$

$A_{sV,min}$, $A_{sV,sp}$ and $A_{sV,s}$ according to Annex D2.

Halfen Insulated Connection HIT-HP/SP

Annex D9

Structural analysis
HIT-HP/SP ZVX (ZDX)

D.1.3.4 HIT-HP/SP DD

Strut-and-tie model of Halfen Insulated Connection HIT-HP/SP DD

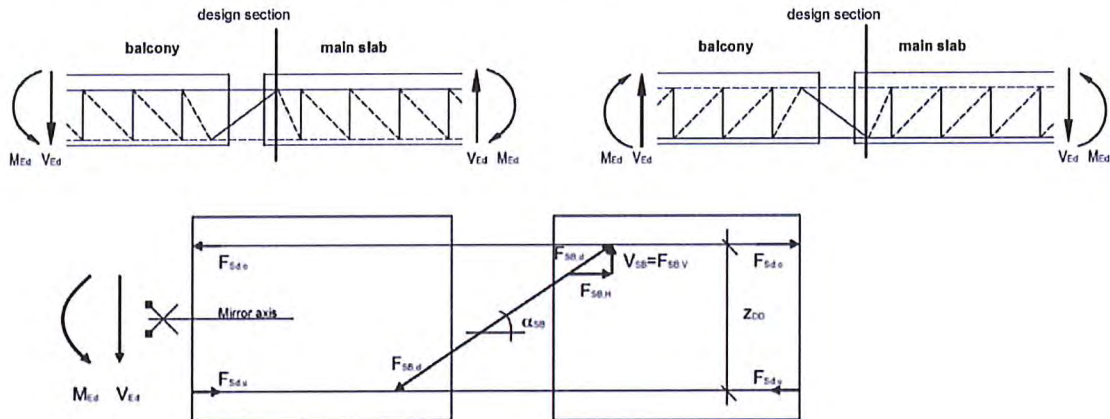

Figure 39: Strut-and-tie model and design section HIT-HP/SP DD

Verifications of the ultimate limit state

$$F_{sd,u} = \frac{M_{Ed}}{z_{DD}} \quad (\text{compression bars})$$

$$F_{sd,o} = \frac{M_{Ed}}{z_{DD}} - F_{SB,H} \quad (\text{tension bars})$$

$$\text{with: } z_{DD} = h - (c_{nom,o} + c_{nom,u} + \varnothing_{s,1})$$

$$F_{SB,H} = \frac{V_{Ed}}{\tan \alpha_{SB}} \quad \text{horizontal tension forces of the shear bars}$$

$$F_{SB,d} = \frac{V_{Ed}}{\sin \alpha_{SB}} \quad (\text{shear bars})$$

Verification of required reinforcement for tensile bars, shear bars

$$A_s = \frac{F_{(..)}}{f_{yd}}$$

Verification of compression bars

$$F_{sd,u} \leq F_{sR,d} \quad F_{sR,d} \text{ according to Annex C1, Table C.2.}$$

On-site vertical reinforcement at the front surfaces of the adjacent components

$$\text{Balcony and main slab side: } A_{sV} = \text{Max} \left\{ \begin{array}{l} A_{sV,min} \\ A_{sV,s} \end{array} \right. \quad A_{sV,min}, A_{sV,s} \text{ according to Annex D2.}$$

Halfen Insulated Connection HIT-HP/SP

Annex D10

Structural analysis
HIT-HP/SP DD

D.1.4 Serviceability limit states

D.1.4.1 Limitation of crack width

- EN 1992-1-1, section 7.3 shall apply
- at the surface of the joint and the load transmission area is no additional verification necessary, if the provisions of this European technical assessment are complied with.

D.1.4.2 Limitation of Deformation

When calculating the deflection, the following influencing factors must be taken into account:

- Elastic deformations of the thermal insulation element and the adjacent slab concrete
- temperature expansions

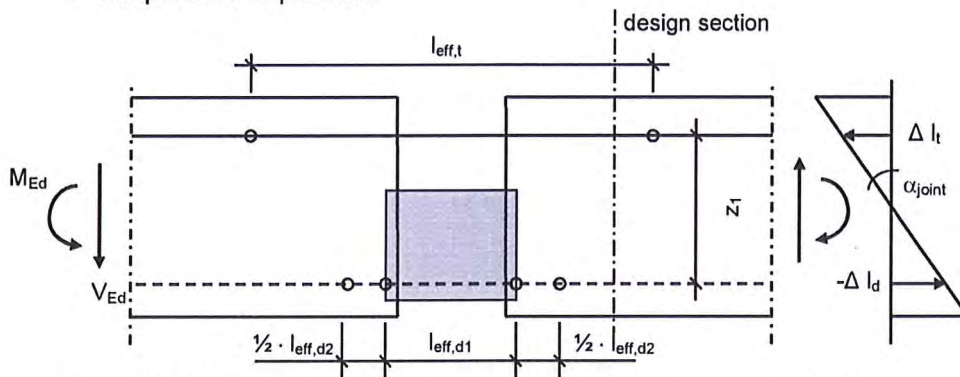

Figure 40: Model to determine the bending deformations in the joint

Angle of rotation in the joint:
$$\tan \alpha_{\text{joint}} = \frac{\Delta l_t - \Delta l_{d1} - \Delta l_{d2}}{z_1} = \frac{\Delta l_t - \Delta l_d}{z_1}$$

Internal lever arm HIT-HP/SP MVX:
$$z_1 = d - \frac{x_c}{2} - 15 \text{ mm}$$

Tension bar strain for $\varnothing_{s1} = \varnothing_{s2}$:
$$\Delta l_t = \varepsilon_t \cdot l_{\text{eff},t} = \frac{\sigma_{s,t}}{E_s} \cdot l_{\text{eff},t}$$

Tension bar strain for $\varnothing_{s1} > \varnothing_{s2}$:
$$\begin{aligned} \Delta l_t &= \varepsilon_{t,ds1} \cdot l_{\text{eff},t,ds1} + \varepsilon_{t,ds2} \cdot l_{\text{eff},t,ds2} \\ &= \frac{\sigma_{s,t,ds1}}{E_{s,ds1}} \cdot l_{\text{eff},t,ds1} + \frac{\sigma_{s,t,ds2}}{E_{s,ds2}} \cdot l_{\text{eff},t,ds2} \end{aligned}$$

where: $l_{\text{eff},t,ds1} = 20 \cdot \varnothing_{s1}$ and $l_{\text{eff},t,ds2} = 280 \text{ mm}$ for HIT-HP
 $l_{\text{eff},t,ds1} = 20 \cdot \varnothing_{s1}$ and $l_{\text{eff},t,ds2} = 320 \text{ mm}$ for HIT-SP

Compression strain of the compression shear bearing:
$$\Delta l_{d1} = -\varepsilon_{d1} \cdot l_{\text{eff},d1}$$

Compression strain of the adjacent slab concrete:
$$\Delta l_{d2} = -\varepsilon_{d2} \cdot l_{\text{eff},d2} = \frac{-\alpha_{l,d2}}{E_{cm}}$$

Halfen Insulated Connection HIT-HP/SP

Annex D11

Structural analysis
Limitation of deformation

Δl_d according to Table D.3.

Concrete strength class	C20/25	C25/30	C30/37	C35/45
Δl_d [mm] for HIT-HP MVX / MVXL	0,160	0,187	0,186	0,185
Δl_d [mm] for HIT-SP MVX / MVXL	0,216	0,254	0,253	0,252

Table D.3 Coefficients Δl_d to calculate the deformation of HIT-HP/SP MVX/MVXL with compression shear bearings

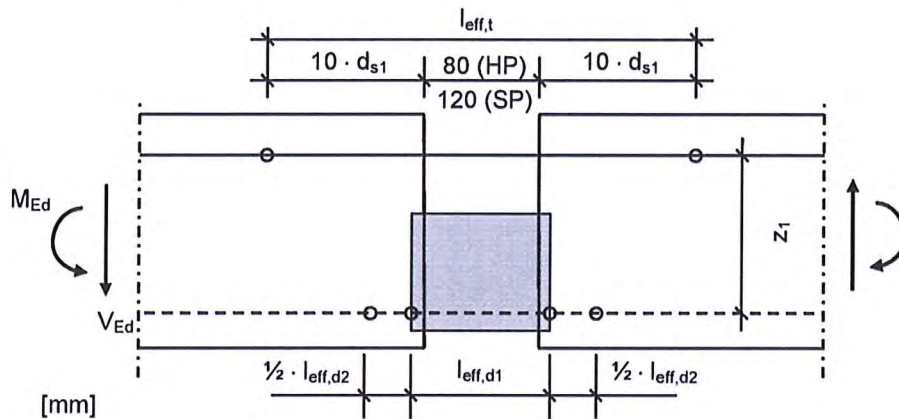

Figure 41: l_{eff} for reinforcing steel B500 NR

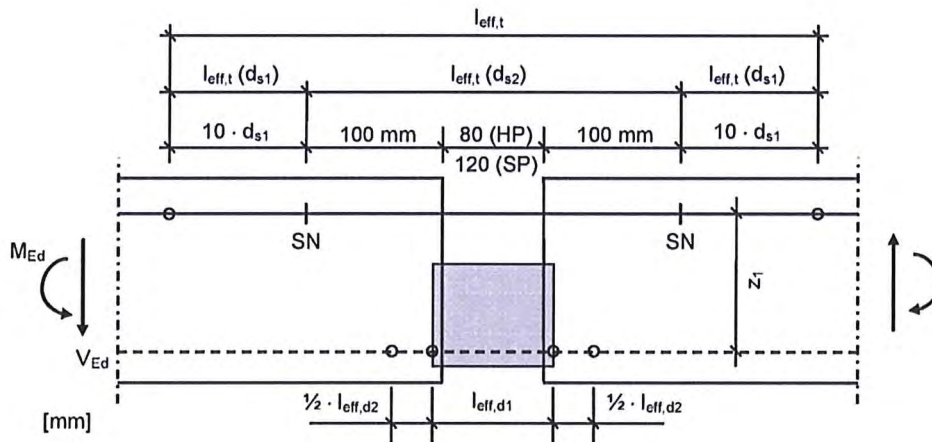

Figure 42: l_{eff} for stainless round steel S 460 and S 690 according to Annex A14

Halfen Insulated Connection HIT-HP/SP

Structural analysis
Limitation of deformation

Annex D12

CONTACT HALFEN WORLDWIDE

HALFEN is represented by subsidiaries in the following countries, please contact us:

Austria	HALFEN Gesellschaft m.b.H. Leonard-Bernstein-Str. 10 1220 Wien	Phone: +43-1-259 6770 E-Mail: office@halfen.at Internet: www.halfen.at	Fax: +43-1-259-677099
Belgium / Luxembourg	HALFEN N.V. Borkelstraat 131 2900 Schoten	Phone: +32-3-658 07 20 E-Mail: info@halfen.be Internet: www.halfen.be	Fax: +32-3-658 15 33
China	HALFEN Construction Accessories Distribution Co.Ltd. Room 601 Tower D, Vantone Centre No. A6 Chao Yang Men Wai Street Chaoyang District Beijing · P.R. China 100020	Phone: +86-10 5907 3200 E-Mail: info@halfen.cn Internet: www.halfen.cn	Fax: +86-10 5907 32 18
Czech Republic	HALFEN s.r.o. Business Center Šafránkova Šafránkova 1238/1 155 00 Praha 5	Phone: +420 - 311-690 060 E-Mail: info@halfen.cz Internet: www.halfen.cz	Fax: +420-235-314 308
France	HALFEN S.A.S. 18, rue Goubet 75019 Paris	Phone: +33-1-445231 00 E-Mail: halfen@halfen.fr Internet: www.halfen.fr	Fax: +33-1-445231 52
Germany	HALFEN Vertriebsgesellschaft mbH Liebigstr. 14 40764 Langenfeld	Phone: +49-2173-970-0 E-Mail: info@halfen.de Internet: www.halfen.de	Fax: +49-2173-970 225
Italy	HALFEN S.r.l. Soc. Unipersonale Via F.lli Bronzetti N° 28 24124 Bergamo	Phone: +39-035-0760711 E-Mail: tecnico@halfen.it Internet: www.halfen.it	Fax: +39-035-0760799
Netherlands	HALFEN b.v. Oostermaat 3 7623 CS Borne	Phone: +31-74-267 14 49 E-Mail: info@halfen.nl Internet: www.halfen.nl	Fax: +31-74-267 26 59
Norway	HALFEN AS Postboks 2080 4095 Stavanger	Phone: +47-51 82 34 00 E-Mail: post@halfen.no Internet: www.halfen.no	
Poland	HALFEN Sp. z o.o. Ul. Obornicka 287 60-691 Poznan	Phone: +48-61-622 14 14 E-Mail: info@halfen.pl Internet: www.halfen.pl	Fax: +48-61-622 14 15
Spain	HALFEN IBERICA, S.L. Polígono Industrial Santa Ana c/ Ignacio Zuloaga 20 28522 Rivas-Vaciamadrid	Phone: +34 916 669 181 E-Mail: info@halfen.es Internet: www.halfen.es	Fax: +34 916 669 661
Sweden	Halfen AB Vädursgatan 5 412 50 Göteborg	Phone: +46-31-98 58 00 E-Mail: info@halfen.se Internet: www.halfen.se	Fax: +46-31-98 58 01
Switzerland	HALFEN Swiss AG Hertistrasse 25 8304 Wallisellen	Phone: +41-44-849 78 78 E-Mail: info@halfen.ch Internet: www.halfen.ch	Fax: +41-44-849 78 79
United Kingdom/ Ireland	HALFEN Ltd. A1/A2 Portland Close Houghton Regis LU5 5AW	Phone: +44 -1582- 47 03 00 E-Mail: info@halfen.co.uk Internet: www.halfen.co.uk	Fax: +44-1582-47 03 04
United States of America	HALFEN USA Inc. PO Box 18687 San Antonio TX 78218	Phone: +1 800.423.91 40 E-Mail: info@halfenusa.com Internet: www.halfenusa.com	Fax: +1 877.683.4910
For countries not listed HALFEN International	HALFEN International GmbH Liebigstr. 14 40764 Langenfeld / Germany	Phone: +49 -2173-970-0 E-Mail: info@halfen.com Internet: www.halfen.com	Fax: +49-2173-970-849

Furthermore HALFEN is represented with sales offices and distributors worldwide. Please contact us: www.halfen.com

NOTES REGARDING THIS CATALOGUE

Technical and design changes reserved. The information in this publication is based on state-of-the-art technology at the time of publication. We reserve the right to make technical and design changes at any time. HALFEN GmbH shall not accept liability for the accuracy of the information in this publication or for any printing errors.

The HALFEN GmbH subsidiaries in Germany, France, the Netherlands, Austria, Poland, Switzerland and the Czech Republic are Quality Management certified according to **ISO 9001:2015**, Certificate no. 202384-2016-AQ-GER-DAKkS.

